

# AXMINSTER

## PROfessional

### SD2080CE Cyclone Dust Collector 230V



CE  
UK  
CA



The packaging is suitable for recycling.  
Please dispose of it in a responsible manner.



EU Countries Only  
Do not dispose of electric tools together with  
household waste material. By law they must be  
collected and recycled separately.



Fully read manual and safety  
instructions before use.  
Save this manual for future  
reference.



Eye protection  
should be worn



Ear protection  
should be worn



Dust mask  
should be worn



Hazard

The symbols above advise the correct safety procedures when using this machine.

### Original Instructions

Code	113330
Version	1
Published Date	30/7/2025

## TABLE OF CONTENTS

Specifications .....	2
Safety Warnings.....	3-7
Electrical Requirements .....	5 & 6, 19
Dust Collector Safety Rules .....	7
Contents of Package .....	8 & 9
Assembly .....	10-18
Operation.....	18
Dust Hazards and Safety.....	7, 19
Wiring Diagram.....	19
Trouble Shooting.....	20
Accessories .....	20
Maintenance .....	21
Notes.....	21, 29, 37, 39
Parts Lists & Diagrams .....	22-36
Warranty .....	38

## SPECIFICATIONS

Model	CD200A	CD300A
Motor .....	1.75HP, TEFC.....	2.5HP, TEFC
Motor Speed (no load).....	2,800 /3,400 RPM.....	2,800 /3,400 RPM
Volts .....	220-240V.....	220-240V
Amps, Hertz, Phase .....	5.8 A , 50/60 Hz, 1 Ph.....	12A , 50/60 Hz, 1 Ph
Air Flow .....	1275/1530 m <sup>3</sup> /hr.....	2080/2499 m <sup>3</sup> /hr
Max. Static Pressure .....	9.5".....	13.2"
Blower Impeller .....	12.5" (310mm) Diameter, Steel.....	14.5" (370mm) Diameter, Steel
Sound Rating @ 3 Feet .....	<81.6 dB.....	<83.7 dB
Canister Filtration Rating .....	1 Micron.....	1 Micron
Canister Pleated Filter Size .....	14" (356mm) x 27-15/16" (709mm).....	16" (406mm) x 32-1/4" (819mm)
Total Pleated Filter Surface .....	64.5 sq/ft.....	86 sq/ft
Plastic Bag Length (installed) .....	21-3/16" (538mm).....	23-5/8" (600mm)
Plastic Bag Capacity .....	2 Cu. Ft.....	3 Cu. Ft
Collection Drum Capacity (Gal.) .....	32 Gal. ....	46 Gal.
Dust Ports / Hose Connections .....	1 @ 6", 2 @ 4".....	1 @ 8", 3 @ 4"
Overall Size (LxWxH) .....	44" x 28" x 68" (1120 x 715 x 1725mm).....	65" x 35" x 78" (1651 x 889 x 1981mm)
Net Weight .....	203 lbs. (92 Kg.).....	258 lbs. (117 Kg.)

**NOTE:** The specifications, photographs, drawings and information in this manual represent the current model when the manual was prepared. Changes and improvements may be made at any time, with no obligation on the part of Rikon Power Tools, Inc. to modify previously delivered units. Reasonable care has been taken to ensure that the information in this manual is correct, to provide you with the guidelines for the proper safety, assembly and operation of this machine.

# SAFETY INSTRUCTIONS

**IMPORTANT!** Safety is the single most important consideration in the operation of this equipment. **The following instructions must be followed at all times.** Failure to follow all instructions listed below may result in electric shock, fire, and/or serious personal injury.

There are certain applications for which this tool was designed. We strongly recommend that this tool not be modified and/or used for any other application other than that for which it was designed. If you have any questions about its application, do not use the tool until you have contacted us and we have advised you.

## SAFETY SYMBOLS



**SAFETY ALERT SYMBOL:** Indicates DANGER, WARNING, or CAUTION. This symbol may be used in conjunction with other symbols or pictographs.



Indicates an imminently hazardous situation, which, if not avoided, could result in death or serious injury.



Indicates a potentially hazardous situation, which, if not avoided, could result in death or serious injury.



Indicates a potentially hazardous situation, which, if not avoided, could result in minor or moderate injury.

**NOTICE:** Shown without Safety Alert Symbol indicates a situation that may result in property damage.

## GENERAL SAFETY

**KNOW YOUR POWER TOOL.** Read the owner's manual carefully. Learn the tool's applications, work capabilities, and its specific potential hazards.

### BEFORE USING YOUR MACHINE

To avoid serious injury and damage to the tool, read and follow all of the Safety and Operating Instructions before operating the machine.

1. **WARNING:** Some dust created by using power tools contains chemicals known to the State of California to cause cancer, birth defects, or other reproductive harm. Some examples of these chemicals are:

- Lead from lead-based paints.
  - Crystalline silica from bricks, cement, and other masonry products.
  - Arsenic and chromium from chemically treated lumber.
- Your risk from these exposures varies, depending on how often you do this type of work. To reduce your exposure to these chemicals: work in a well ventilated area and work with approved safety equipment, such as those dust masks that are specially designed to filter out microscopic particles.

2. **READ** the entire Owner's Manual. **LEARN** how to use the tool for its intended applications.

3. **GROUND ALL TOOLS.** If the tool is supplied with a 3 prong plug, it must be plugged into a 3-contact electrical receptacle. The 3rd prong is used to ground the tool and provide protection against accidental electric shock. **DO NOT** remove the 3rd prong. See Grounding Instructions on the following pages.

4. **AVOID A DANGEROUS WORKING ENVIRONMENT.** **DO NOT** use electrical tools in a damp environment or expose them to rain.

5. **DO NOT** use electrical tools in the presence of flammable liquids or gases.

6. **ALWAYS** keep the work area clean, well lit, and organized. **DO NOT** work in an environment with floor surfaces that are slippery from debris, grease, and wax.

7. **KEEP VISITORS AND CHILDREN AWAY. DO NOT** permit people to be in the immediate work area, especially when the electrical tool is operating.

8. **DO NOT FORCE THE TOOL** to perform an operation for which it was not designed. It will do a safer and higher quality job by only performing operations for which the tool was intended.

9. **WEAR PROPER CLOTHING. DO NOT** wear loose clothing, gloves, neckties, or jewelry. These items can get caught in the machine during operations and pull the operator into the moving parts. The user must wear a protective cover on their hair, if the hair is long, to prevent it from contacting any moving parts.

10. **CHILDPROOF THE WORKSHOP AREA** by removing switch keys, unplugging tools from the electrical receptacles, and using padlocks.

11. **ALWAYS UNPLUG THE TOOL FROM THE ELECTRICAL RECEPTACLE** when making adjustments, changing parts or performing any maintenance.

## SAFETY INSTRUCTIONS

12. **KEEP PROTECTIVE GUARDS IN PLACE AND IN WORKING ORDER.**

13. **AVOID ACCIDENTAL STARTING.** Make sure that the power switch is in the "OFF" position before plugging in the power cord to the electrical receptacle.

14. **REMOVE ALL MAINTENANCE TOOLS** from the immediate area prior to turning "ON" the machine.

15. **USE ONLY RECOMMENDED ACCESSORIES.** Use of incorrect or improper accessories could cause serious injury to the operator and cause damage to the tool. If in doubt, check the instruction manual that comes with that particular accessory.

16. **NEVER LEAVE A RUNNING TOOL UNATTENDED.** Turn the power switch to the "OFF" position. **DO NOT** leave the tool until it has come to a complete stop.

17. **DO NOT STAND ON A TOOL.** Serious injury could result if the tool tips over, or you accidentally contact the tool.

18. **DO NOT** store anything above or near the tool where anyone might try to stand on the tool to reach it.

19. **MAINTAIN YOUR BALANCE. DO NOT** extend yourself over the tool. Wear oil resistant rubber soled shoes. Keep floor clear of debris, grease, and wax.

20. **MAINTAIN TOOLS WITH CARE.** Always keep tools clean and in good working order. Keep all blades and tool bits sharp, dress grinding wheels and change other abrasive accessories when worn.

21. **EACH AND EVERY TIME, CHECK FOR DAMAGED PARTS PRIOR TO USING THE TOOL.** Carefully check all guards to see that they operate properly, are not damaged, and perform their intended functions. Check for alignment, binding or breaking of moving parts. A guard or other part that is damaged should be immediately repaired or replaced.

22. **DO NOT OPERATE TOOL WHILE TIRED, OR UNDER THE INFLUENCE OF DRUGS, MEDICATION OR ALCOHOL.**

23. **SECURE ALL WORK.** Use clamps or jigs to secure the work piece. This is safer than attempting to hold the work piece with your hands.

24. **STAY ALERT, WATCH WHAT YOU ARE DOING, AND USE COMMON SENSE WHEN OPERATING A POWER TOOL.**

A moment of inattention while operating power tools may result in serious personal injury.

25. **ALWAYS WEAR A DUST MASK TO PREVENT INHALING DANGEROUS DUST OR AIRBORNE PARTICLES,** including wood dust, crystalline silica dust and asbestos dust. Direct particles away from face and body. Always operate tool in well ventilated area and provide for proper dust removal. Use dust collection system wherever possible. Exposure to the dust may cause serious and permanent respiratory or other injury, including silicosis (a serious lung disease), cancer, and death. Avoid breathing the dust, and avoid prolonged contact with dust. Allowing dust to get into your mouth or eyes, or lay on your skin may promote absorption of harmful material. Always use properly fitting NIOSH/OSHA approved respiratory protection appropriate for the dust exposure, and wash exposed areas with soap and water.

26. **USE A PROPER EXTENSION CORD IN GOOD CONDITION.** When using an extension cord, be sure to use one heavy enough to carry the current your product will draw. The table on the following page shows the correct size to use depending on cord length and nameplate amperage rating. If in doubt, use the next heavier gauge. The smaller the gauge number, the larger diameter of the extension cord. If in doubt of the proper size of an extension cord, use a shorter and thicker cord. An undersized cord will cause a drop in line voltage resulting in a loss of power and overheating.  
**USE ONLY A 3-WIRE EXTENSION CORD THAT HAS A 3-PRONG GROUNDING PLUG AND A 3-POLE RECEPTACLE THAT ACCEPTS THE TOOL'S PLUG.**

27. **SAVE THESE INSTRUCTIONS.** Refer to them frequently and use them to instruct others.

# SAFETY INSTRUCTIONS - CD200A

## ELECTRICAL SAFETY

**⚠ WARNING:** THIS TOOL MUST BE GROUNDED WHILE IN USE TO PROTECT THE OPERATOR FROM ELECTRIC SHOCK.

**IN THE EVENT OF A MALFUNCTION OR BREAKDOWN,** grounding provides the path of least resistance for electric current and reduces the risk of electric shock. This tool is equipped with an electric cord that has an equipment grounding conductor and requires a grounding plug (not included). The plug **MUST** be plugged into a matching electrical receptacle that is properly installed and grounded in accordance with **ALL** local codes and ordinances.

**DO NOT MODIFY ANY PLUG.** If it will not fit the electrical receptacle, have the proper electrical receptacle installed by a qualified electrician.

**IMPROPER ELECTRICAL CONNECTION** of the equipment grounding conductor can result in risk of electric shock. The conductor with the green insulation (with or without yellow stripes) is the equipment grounding conductor. **DO NOT** connect the equipment grounding conductor to a live terminal if repair or replacement of the electric cord or plug is necessary.

**CHECK** with a qualified electrician or service personnel if you do not completely understand the grounding instructions, or if you are not sure the tool is properly grounded when installing or replacing a plug.

**USE ONLY A 3-WIRE EXTENSION CORD THAT HAS THE PROPER TYPE OF A 3-PRONG GROUNDING PLUG THAT MATCHES THE MACHINE'S 3-PRONG PLUG AND ALSO THE 3-POLE RECEPTACLE THAT ACCEPTS THE TOOL'S PLUG. \***

**REPLACE A DAMAGED OR WORN CORD IMMEDIATELY.**

This tool is intended for use on a circuit that has an electrical receptacle as shown in **FIGURE A**. It shows a 3-wire electrical plug and electrical receptacle that has a grounding conductor. If a properly grounded electrical receptacle is not available, an adapter as shown in **FIGURE B** can be used to temporarily connect this plug to a 2-contact ungrounded receptacle. The adapter has a rigid lug extending from it that **MUST** be connected to a permanent earth ground, such as a properly grounded receptacle box. **THIS ADAPTER IS PROHIBITED IN CANADA.**

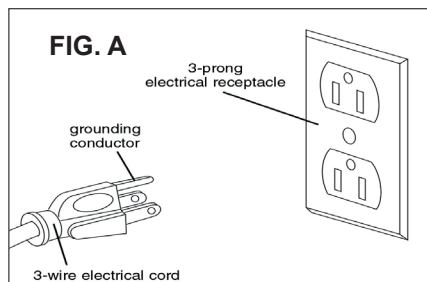

## EXTENSION CORDS

**⚠ WARNING:** THE USE OF AN EXTENSION CORD WITH THIS MACHINE IS NOT RECOMMENDED. For best power and safety, plug the machine directly into a dedicated, grounded electrical outlet that is within the supplied cord length of the machine.

If an extension cord needs to be used, it should only be for a limited operation of the machine. The extension cord should be as short as possible in length, and have a minimum gauge size of 14AWG.

**⚠ WARNING:** Check extension cords before each use. If damaged replace immediately. Never use a tool with a damaged cord, since touching the damaged area could cause electrical shock, resulting in serious injury.

Use a proper extension cord. Only use cords listed by Underwriters Laboratories (UL). Other extension cords can cause a drop in line voltage, resulting in a loss of power and overheating of tool. When operating a power tool outdoors, use an outdoor extension cord marked "W-A" or "W". These cords are rated for outdoor use and reduce the risk of electric shock.

### MINIMUM RECOMMENDED GAUGE FOR EXTENSION CORDS (AWG)

120 VOLT OPERATION ONLY				
	25' LONG	50' LONG	100' LONG	150' LONG
0 to 6 Amps	18 AWG	16 AWG	16 AWG	14 AWG
6 to 10 Amps	18 AWG	16 AWG	14 AWG	12 AWG
10 to 12 Amps	16 AWG	16 AWG	14 AWG	12 AWG

**⚠ WARNING:** Keep the extension cord clear of the working area. Position the cord so that it will not get caught on lumber, tools or other obstructions while you are working with your power tool.

\* Canadian electrical codes require extension cords to be certified SJT type or better.

\*\* The use of an adapter in Canada is not acceptable.

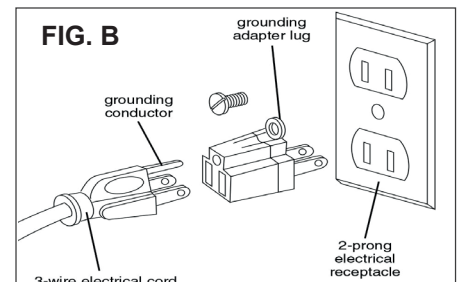

# SAFETY INSTRUCTIONS - CD300A

## ELECTRICAL SAFETY

**⚠ WARNING** THIS TOOL REQUIRES THE USE OF A 230V PLUG (NOT INCLUDED), AND MUST BE GROUNDED WHILE IN USE TO PROTECT THE OPERATOR FROM ELECTRIC SHOCK.

**IN THE EVENT OF A MALFUNCTION OR BREAKDOWN,** grounding provides the path of least resistance for electric current and reduces the risk of electric shock. This tool is equipped with an electric cord that has an equipment grounding conductor and requires a grounding plug (not included). The plug **MUST** be plugged into a matching electrical receptacle that is properly installed and grounded in accordance with **ALL** local codes and ordinances.

**DO NOT MODIFY ANY PLUG.** If it will not fit the electrical receptacle, have the proper electrical receptacle installed by a qualified electrician.

**REPLACE A DAMAGED OR WORN CORD OR PLUG IMMEDIATELY.**

**IMPROPER ELECTRICAL CONNECTION** of the equipment grounding conductor can result in risk of electric shock. The conductor with the green insulation (with or without yellow stripes) is the equipment grounding conductor. **DO NOT** connect the equipment grounding conductor to a live terminal if repair or replacement of the electric cord or plug is necessary.

**CHECK** with a qualified electrician or service personnel if you do not completely understand the grounding instructions, or if you are not sure the tool is properly grounded when installing or replacing a plug.

This tool is intended for use on a circuit that has a 230 volt electrical receptacle. **FIGURE A** shows the type of the 230V, 3-wire electrical plug and electrical receptacle that has a grounding conductor that is required.

\* Canadian electrical codes require extension cords to be certified SJT type or better.

\*\* The use of an adapter in Canada is not acceptable.

Sample of 230 volt plug required for this machine.

FIG. A



NEMA 6-15P

Consult a qualified electrician if the distance of the machine from the electrical panel is greater than 30 feet.

## EXTENSION CORDS

**⚠ WARNING:** USE OF AN EXTENSION CORD WITH THIS MACHINE IS NOT RECOMMENDED. FOR BEST POWER AND SAFETY, PLUG THE MACHINE DIRECTLY INTO A DEDICATED GROUNDED ELECTRICAL OUTLET THAT IS WITHIN THE SUPPLIED CORD LENGTH OF THE MACHINE.

**IF AN EXTENSION CORD NEEDS TO BE USED, IT SHOULD ONLY BE FOR LIMITED OPERATION OF THE MACHINE. THE EXTENSION CORD SHOULD BE AS SHORT AS POSSIBLE IN LENGTH, AND HAVE A MINIMUM GAUGE SIZE OF 14AWG.**

**USE ONLY A 3-WIRE EXTENSION CORD THAT HAS THE PROPER TYPE OF A 3-PRONG GROUNDING PLUG THAT MATCHES THE MACHINE'S 3-PRONG PLUG AND ALSO THE 3-POLE RECEPTACLE THAT ACCEPTS THE TOOL'S PLUG.**

**⚠ WARNING:** Check extension cords before each use. If damaged replace immediately. Never use a tool with a damaged cord, since touching the damaged area could cause electrical shock, resulting in serious injury.

Use a proper extension cord. Only use cords listed by Underwriters Laboratories (UL). Other extension cords can cause a drop in line voltage, resulting in a loss of power and overheating of tool. When operating a power tool outdoors, use an outdoor extension cord marked "W-A" or "W". These cords are rated for outdoor use and reduce the risk of electric shock.

**⚠ WARNING:** Keep the extension cord clear of the working area. Position the cord so that it will not get caught on lumber, tools or other obstructions while you are working with a power tool.

# SAFETY INSTRUCTIONS

## SPECIFIC SAFETY INSTRUCTIONS FOR DUST COLLECTORS

This machine is intended for the collection of chips, shavings and dust from the surfacing, cutting and sanding of natural wood, plywood, plastics and other man-made wood based composites. It is for collecting DRY materials only. Any other use not as specified, including modification of the machine or use of parts not tested and approved by the equipment manufacturer, can cause unforeseen damage and invalidate the warranty.

**ATTENTION:** Use of this dust collector still presents risks that cannot be eliminated by the manufacturer. Therefore, the user must be aware that wood working machines are dangerous if not used with care and all safety precautions are adhered to.

1. Do not operate this machine until you have read all of the following instructions.
2. Do not attempt to operate this machine until it is completely assembled.
3. Do not turn ON this machine if any pieces are missing or damaged.
4. If you are not familiar with the operation of the machine, obtain assistance from a qualified person.
5. It is highly recommended that this machine be placed on a sturdy vertical surface.
6. This machine must be properly grounded.
7. Always wear approved protective eye, hearing and respiratory protection when operating this machine.
8. Always make sure the power switch is in the OFF position prior to plugging in the machine.
9. Always make sure the power switch is in the OFF position and the machine is unplugged when doing any cleaning, assembly, setup operations, or when not in use.
10. DO NOT use the dust collector for collecting liquids, substances impregnated with liquids, metals, gasoline or potentially flammable or combustible substances.
11. DO NOT use the dust collector to dissipate fumes or smoke. NEVER pick up any material that is burning or smoking, such as cigarettes, matches or hot ashes.
12. DO NOT use the dust collector without a filter canister and dust collector bag securely in place.
13. DO NOT use the dust collector with unused intake ports uncapped. Always cover exposed intake ports.
14. Always wear a dust mask when cleaning or working near a dust collector.
15. Make sure all machine parts, hose connections and bags are securely tightened before operating the machine. Periodically check bags and hoses for rips or tears. If present, repair or replace immediately.
16. The use of any accessories or attachments not recommended may cause injury to you and damage your machine.
17. Never reach inside of a running machine. Always keep your hands, body parts and clothing clear of openings and moving parts such as impellers, fans and hose intake openings.
18. Do not clear any hose blockage while the machine is running. Stop the machine, unplug it from the power source, and then remove the blockage in the hose.
19. Do not expose the machine to rain or use in damp locations.
20. Keep these instructions for future reference.

**This owner's manual is not a teaching aid and is intended to show assembly, adjustments, and general use.**

### CALIFORNIA PROPOSITION 65 WARNING



**WARNING:** Drilling, sawing, sanding or machining wood products can expose you to wood dust, a substance known to the State of California to cause cancer. Avoid inhaling wood dust or use a dust mask or other safeguards for personal protection. For more information go to [www.P65Warnings.ca.gov/wood](http://www.P65Warnings.ca.gov/wood)

# CONTENTS OF PACKAGE - CD200A

**NOTE:** Contents of Package and Assembly are shown for the CD200A 1.75HP Cyclone only. Assembly steps for the CD300A 2.5HP Cyclone are the same. Parts lists at the rear of this manual will show differences in both units.

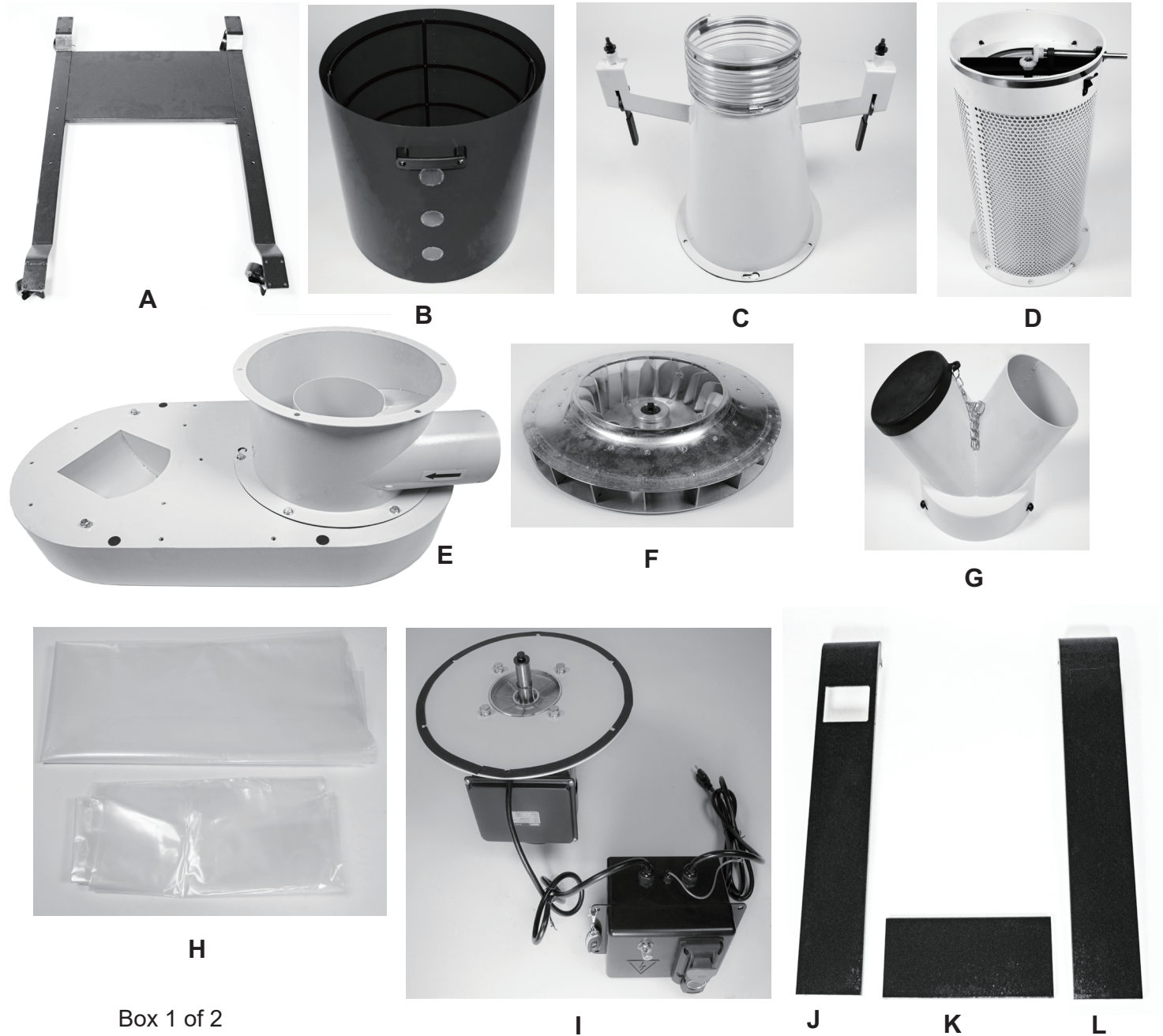

- Box 1 of 2
- A Base Panel with Casters
  - B Collection Drum
  - C Separator Funnel
  - D Filter Cartridge Assembly
  - E Dust Plenum w/ Cyclonic Separator

- F Impeller
- G 6" to Dual 4" Inlet
- H Collection Bags
- I Motor & Switch Assembly

- Box 2 of 2
- J Left Support Panel
  - K Panel Cross Brace
  - L Right Support Panel

Parts Diagram and Parts List are listed on Pages 22 through 36.

### Additional Tools required - not supplied

#2 Phillips Screwdriver

## CONTENTS OF PACKAGE - CD200A

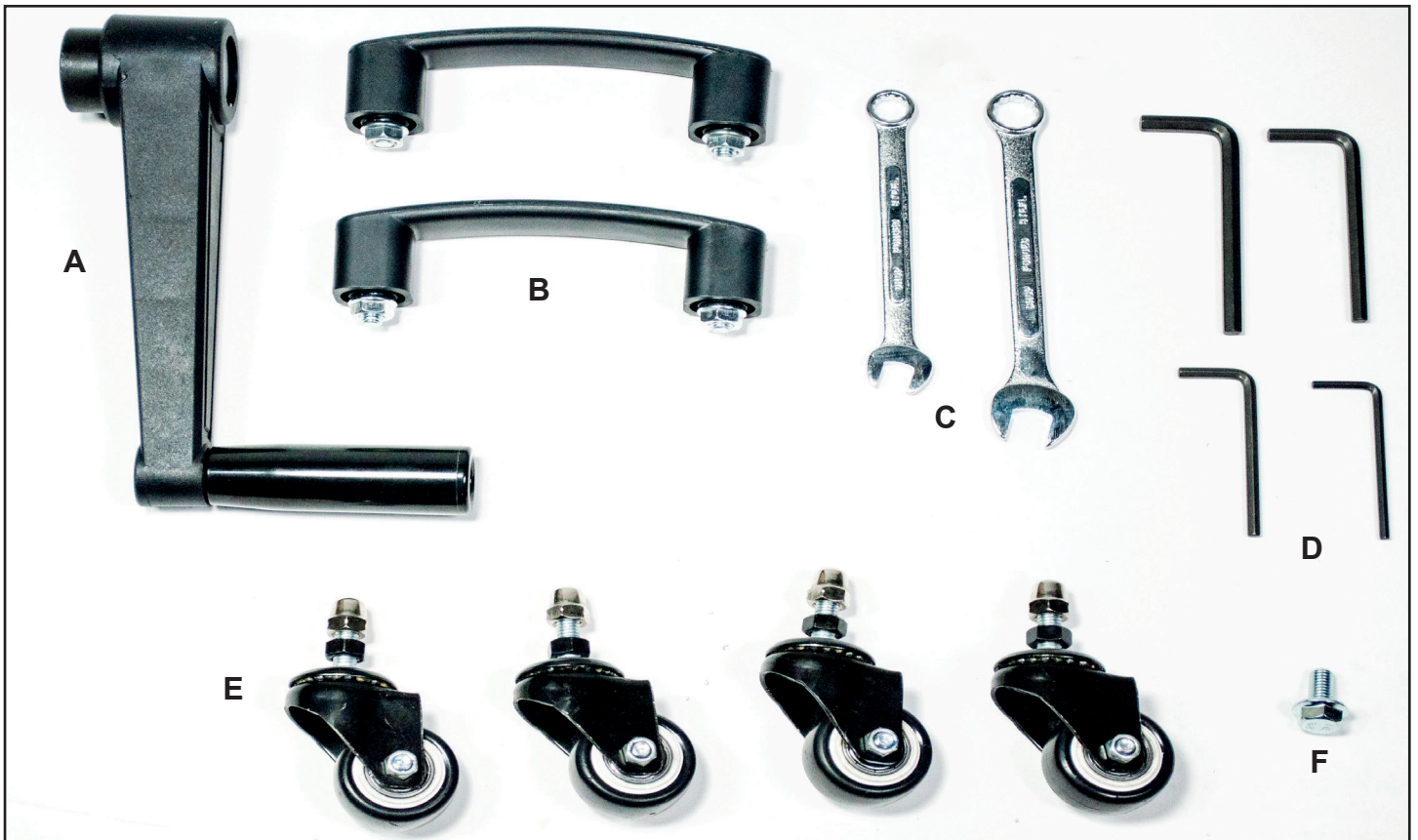

### Hardware Pack

- A Filter Cleaning Crank Handle
- B Handles for Support Panels
- C Wrenches - 10mm & 13mm
- D Hex Wrenches - 3mm, 4mm, 5mm, 6mm
- E Casters for Collector Drum (x4)
- F Hex Head Flange Bolt M8X16 (x44)

Parts Diagram and  
Parts List are listed  
on Pages 22 through 36.

Models #CD200A and #CD300A Cyclone Dust Collectors are shipped complete in two boxes.

### Unpacking and Clean-up

1. Carefully remove all contents from the shipping carton. Compare the contents with the list of contents to make sure that all of the items are accounted for, before discarding any packing material. Place parts on a protected surface for easy identification and assembly. DO NOT turn your machine ON if any of these items are missing. You may cause injury to yourself or damage to the machine.
2. Report any shipping damage to your local distributor. Take photographs for any possible insurance claims.
3. Clean any rust protected surfaces with ordinary house hold type grease or spot remover. Do not use; gasoline, paint thinner, mineral spirits, etc. These may damage painted surfaces.
4. Set packing material and shipping carton aside. Do not discard until the machine has been set up and is running properly.

# ASSEMBLY

**NOTE:** The parts listed in the instructions refer to either the Contents of Package on page 8, or the Parts Diagram & Parts List on pages 22 thru 36.

**WARNING** THE MACHINE MUST NOT BE PLUGGED IN AND THE POWER SWITCH MUST BE IN THE OFF POSITION UNTIL ASSEMBLY IS COMPLETE.

## BASE PANEL, LEFT & RIGHT SUPPORT PANEL ASSEMBLY

Locate the following parts in Figure 1:

- Base Panel with Casters (A, Parts Diagram #1D)
- Left Support Panel (x1) (J, Parts Diagram #36A)
- Panel Cross Brace (x1) (K, Parts Diagram #45A)
- Right Support Panel (x1) (L, Parts Diagram #35A)
- Hex Head Flange Bolt M8X16 (x10) (Parts Diagram #45A) Not shown in FIG. 1.
- 13mm Wrench (Included)

**NOTE:** Leave Flange Bolts slightly loose for panel alignment and installation of the Dust Plenum.

1. Lay the Base Panel on a level floor and lock the casters. Refer to photo of finished Support Panel assembly below before proceeding to step 2.
2. Secure the Left Support Panel Support to the Base Panel using QTY 3 M8X16 Hex Head Flange Bolts. Shown, FIG. 2.
3. Install the Panel Cross Brace to the Left Panel Support with QTY 2 M8X16 Hex Head Flange Bolts. Shown, FIG. 3.
4. Secure the Right Support Panel Support to the Base Panel *and* Panel Cross Brace using QTY 5 M8X16 Hex Head Flange Bolts.

**Finished Support Panel assembly shown:**

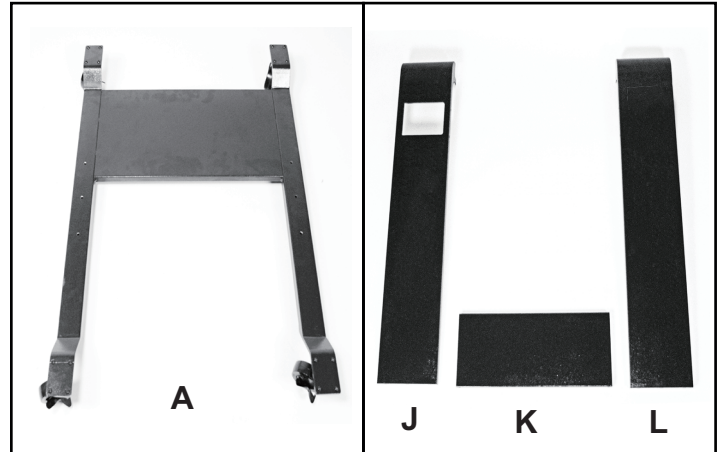
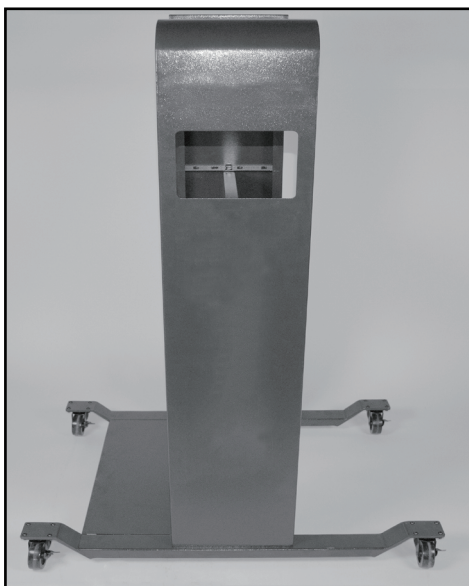

FIG. 1

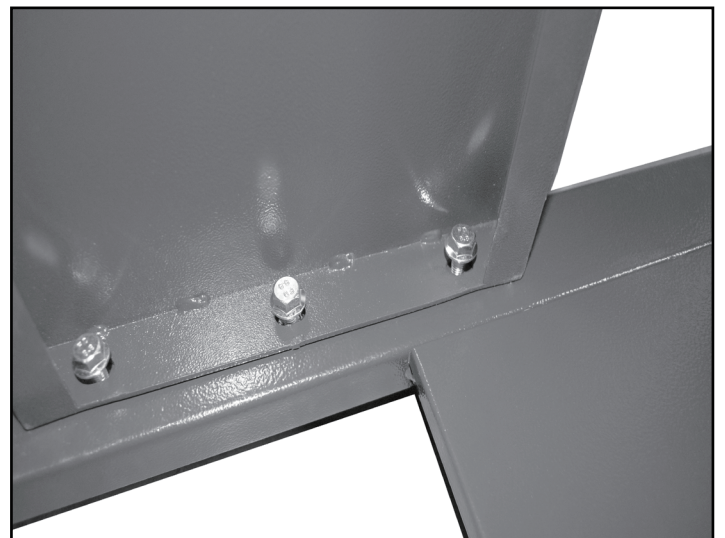

FIG. 2



FIG. 3

# ASSEMBLY

## MOUNTING THE DUST PLENUM

Locate the following parts:

- Dust Plenum w/ Cyclonic Separator (E - Page 8, Parts List #1A,2A)
- Hex Head Flange Bolt M8X16 (x4) (Parts List #44A)
- 13mm Wrench (Included)
- Finished Support Panel Assembly

**NOTE:** Assistance may be required for this step. If attempting installation alone, remove the Cyclonic Separator (A-Fig. 5) from the Dust Plenum before lifting onto the Support Panel assembly. FIGS. 5 & 6.

1. Orientate the Support Panel Assembly as shown below. Figure 4.

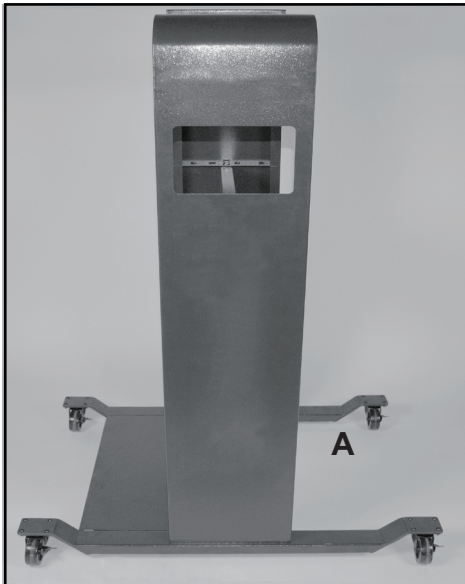

FIG. 4

2. Lift the Dust Plenum and rest on the ledge (Fig. 7) of the Support Panel Assembly and secure with 4 M8X16 Hex Head Flange Bolts (Fig. 8). Make sure the Cyclonic Separator is overhanging the open section of the baseplate (A-Fig. 4). Underside of the Dust Plenum shown Fig. 8.

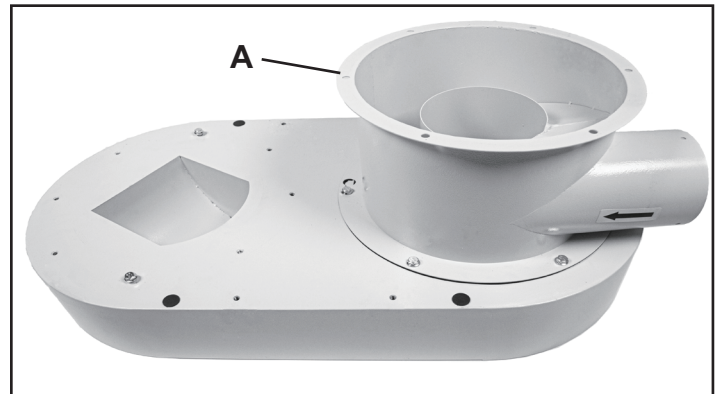

FIG. 5

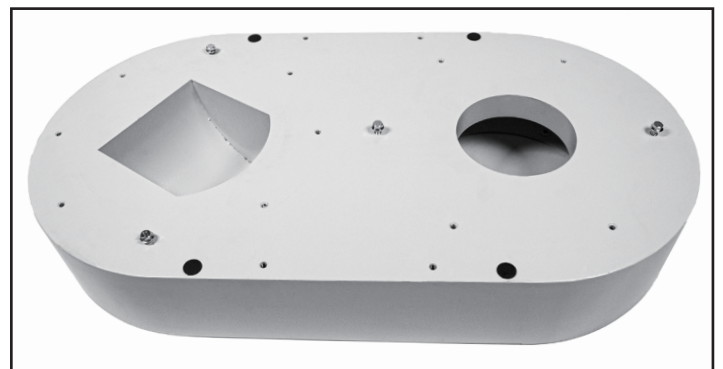

FIG. 6

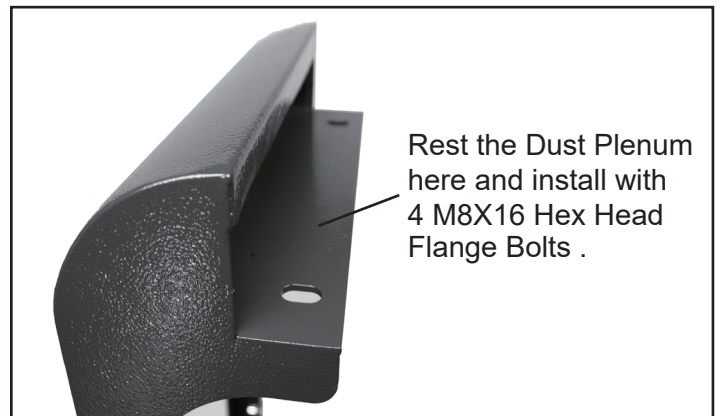

FIG. 7

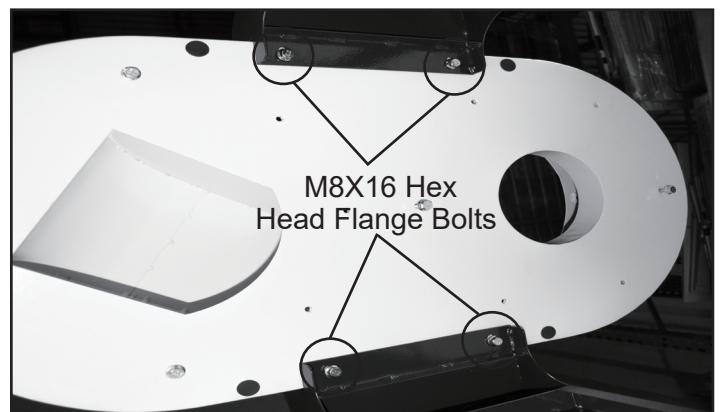

FIG. 8

# ASSEMBLY

## ASSEMBLE IMPELLER TO MOTOR

Locate the following parts:

- Motor & Switch Assembly (I - Page 8)
- Impeller (F - Page 8)
- Hex Head Bolt M8X25 (A - Fig. 9/Parts List #11B)
- Spring Washer 8mm (B - Fig. 9/Parts List #10B)
- Big Washer 8mm (C - Fig. 9/Parts List #9B)
- 13mm Wrench (Included)
- 3mm Hex Wrench (Included)

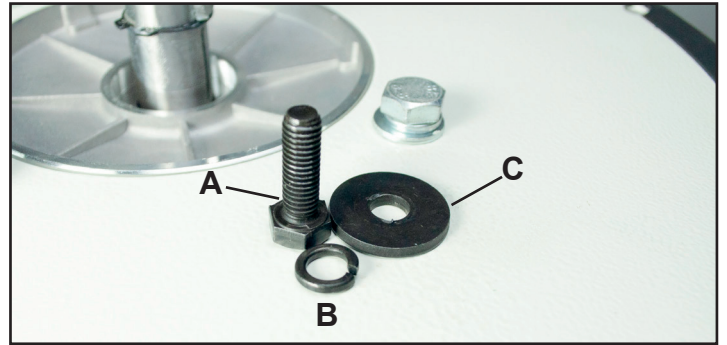

FIG. 9

**⚠ WARNING** THE MACHINE MUST NOT BE PLUGGED IN AND THE POWER SWITCH MUST BE IN THE OFF POSITION UNTIL ASSEMBLY IS COMPLETE.

1. Install the Impeller onto the Motor Shaft. Ensure to engage the motor shaft key into the slot of the Impeller.

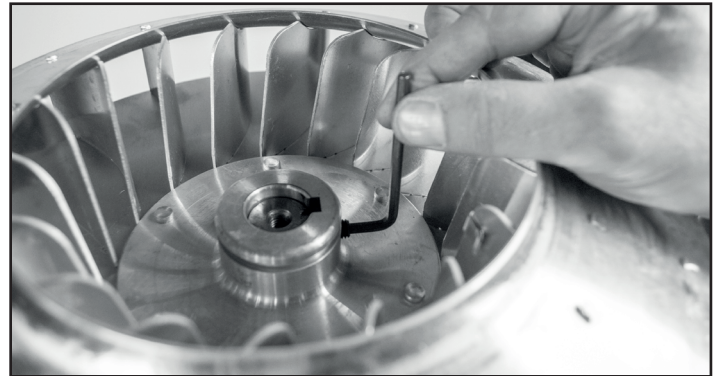

FIG. 10

2. Tighten the M8x12 Hex Head Screw, with the 3mm Hex Wrench, locking the Impeller to the motor shaft key. Fig. 10.

3. Install the M8X25 Hex Head Bolt, 8mm Spring Washer and 8mm Big Washer to the end of the motor shaft using the 13mm wrench. Fig. 11.

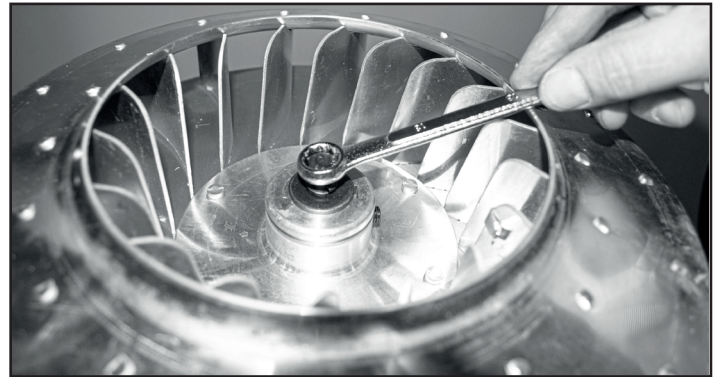

FIG. 11

## INSTALL THE MOTOR TO THE DUST PLENUM

1. With assistance, lift the Motor and Impeller assembly and install onto the Dust Plenum. Rotate then assembly until the motor wire junction box faces the center of the Dust Plenum. Fig. 12.

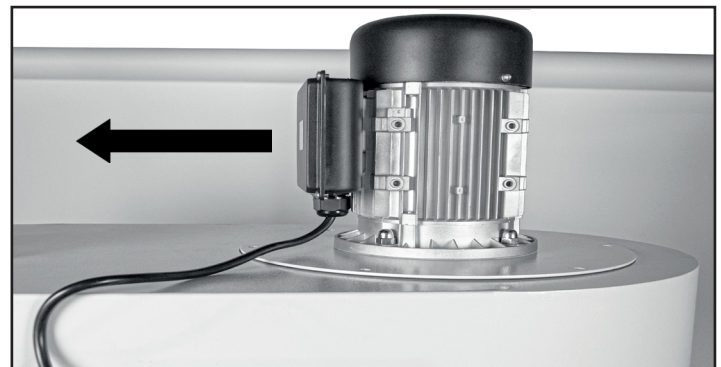

FIG. 12

CONTINUED ON PAGE 13

# ASSEMBLY

## INSTALL THE MOTOR TO THE DUST PLENUM

CONTINUED FROM PAGE 12

Locate the following parts:

- Hex Head Bolt M8X16 (x6) (Parts List #3B)
- 13mm Wrench (Included)

2. Align the six holes in the Motor Mounting plate with the six holes in the Dust Plenum.

3. Install six M8X16 Hex Head Bolts to secure the Motor to the Dust Plenum. Fig. 13.



FIG. 13



**WARNING** THE MACHINE MUST NOT BE PLUGGED IN AND THE POWER SWITCH MUST BE IN THE OFF POSITION UNTIL ASSEMBLY IS COMPLETE.

## INSTALLING THE SWITCH BOX ASSEMBLY

Locate the following parts:

- Hex Head Bolt M8X16 (x4) (Parts List #44A)
- 13mm Wrench (Included)
- Phillips Head Screwdriver (Not Included)

1. Install the green ground wire to the inside of the Right Support Panel just behind the Switch Box opening. Locate the screw (pre-installed) and terminate the green wire next to the ground symbol. Fig. 14.



FIG. 14

2. Place the Switch Box through the rectangular hole in the Right Support Panel. Secure the Switch Box to the Right Support Panel with four M8X16 Hex Head Bolts. Fig. 15.



FIG. 15

3. Front of switch will be exposed through the rectangular hole in the Right Support Panel. Example shown Fig. 16.

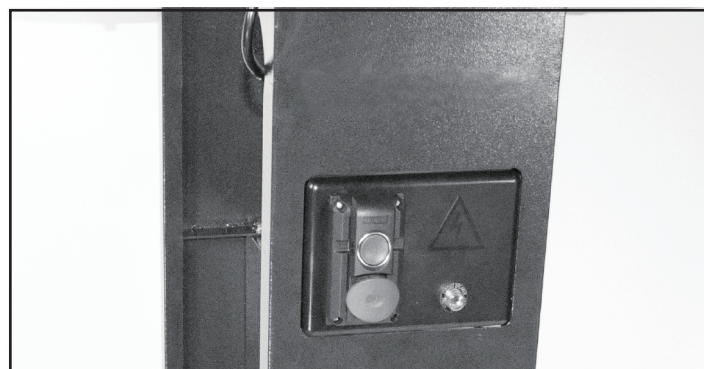

FIG. 16

# ASSEMBLY

## ASSEMBLE CYCLONIC SEPARATOR TO THE DUST PLENUM

**NOTE:** This step is only necessary if the Cyclonic Separator was removed for the installation of the Dust Plenum to the Support Panel Assembly, page 10, Fig. 5.

Locate the following parts:

- Cyclonic Separator (B - Page 8, Parts List #2A)
- Hex Head Flange Bolt M8X16 (x6) (Parts List #44A)
- 13mm Wrench (Included)

1. Install two M8X16 Hex Head Flange Bolts to the underside of the Dust Plenum as shown, A-Fig. 17. Leave the bolts loose at this time, providing a 1/4" space between the head of the bolt and body of the Dust Plenum.

2. Lift the Cyclonic Separator to the Dust Plenum, taking note of the two key hole slots cut into the flange. Engage the two bolts (installed in the previous step) into the key hole slots. Rotate the Cyclonic Separator to the right, temporarily holding it in place. Fig. 18.

3. Install the four remaining M8X16 Hex Head Flange Bolts using the 13mm wrench, securing the Cyclonic Separator to the Dust Plenum.

## ASSEMBLE SEPARATOR FUNNEL TO THE CYCLONIC SEPARATOR

Locate the following parts:

- Separator Funnel (C - Page 8, Parts List #27A)
- Hex Flange Nut M8 (x6) (Parts List #34A)
- Hex Head Flange Bolt M8X16 (x6) (Parts List #44A)
- 13mm Wrench (Included)

1. Install the Separator Funnel to the Cyclonic Separator using six M8X16 Hex Head Flange Bolts and six M8 Hex Flange Nuts as shown, A-Fig. 19.

2. Make sure the locking handles for the Collection Drum are oriented to lock away from the Cyclone, towards the right. Fig. 20.

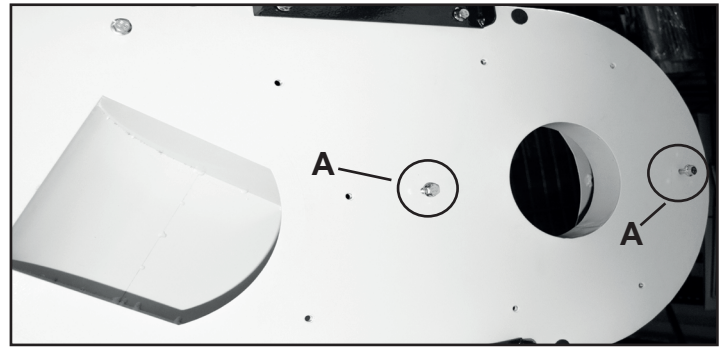

FIG. 17



**WARNING** THE MACHINE MUST NOT BE PLUGGED IN AND THE POWER SWITCH MUST BE IN THE OFF POSITION UNTIL ASSEMBLY IS COMPLETE.

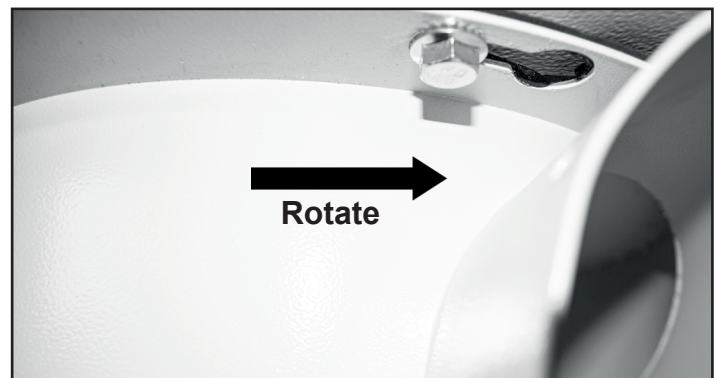

FIG. 18



FIG. 19



FIG. 20

# ASSEMBLY

## INSTALLING THE MOVING HANDLES

Locate the following parts:

- Handles (x2) (B Page - 9, Parts List #37A)
- Hex Flange Nut M8 (x4) (Parts List #34A)
- Hex socket Cap Screw M8X30 (x4) (Parts List #38A)
- 5mm Hex Wrench (Included)

1. Install the two Moving Handles to the left and right Support Panels with the provided hardware. Fig. 21



FIG. 21

## INSTALLING THE FILTER CARTRIDGE ASSEMBLY

Locate the following parts:

- Filter Cartridge Assembly (D - Page 8, Parts List #1C & #2C)
- Hex Head Flange Bolt M8X16 (x8) (Parts List #3C)
- 13mm Wrench (Included)

1. Install two M8X16 Hex Head Flange Bolts to the underside of the Dust Plenum as shown, A-Fig. 22. Leave the bolts loose at this time, providing a 1/4" space between the head of the bolt and body of the Dust Plenum.

2. Lift the Filter Cartridge Assembly to the Dust Plenum, taking note of the two key hole slots cut into the flange. Engage the bolts (installed in the previous step) into the key hole slots. Rotate the Filter Cartridge Assembly to the right, temporarily holding it in place. Fig. 23.

3. Make sure that the filter cleaning handle stem is oriented to the right as shown in Figure 24.

4. Install the six remaining M8X16 Hex Head Flange Bolts using the 13mm wrench, securing the Filter Cartridge Assembly to the Dust Plenum.

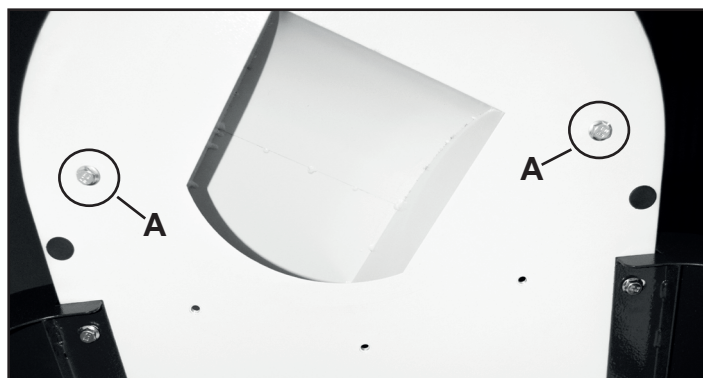

FIG. 22

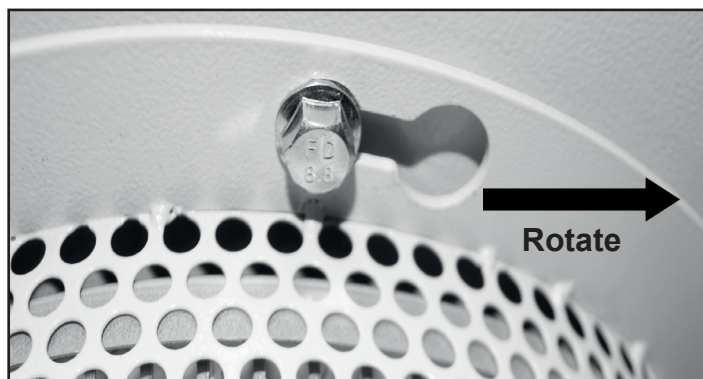

FIG. 23



FIG. 24

# ASSEMBLY

## INSTALLING THE FILTER PLASTIC DUST BAG

1. Install the (smaller) clear plastic collection bag (H - Page 8) onto the bottom rim of the Filter Cartridge. Temporarily secure it in place with the provided spring clips.
2. Install the Strap Clamp (#8C) around the canister and over the plastic bag. Lock it in place with the strap clamp. Engage the catch end of the strap with the clasp in the appropriate slot to ensure a tight fit, and press the lever with the palm of your hand to lock the clamp. Figure 25.

**NOTE:** To release the clamp, lift up on the lever. If the lever is hard to disengage, simply use a flat head screwdriver to pry the lever upwards.



FIG. 25

## ASSEMBLING THE COLLECTION DRUM COVER

Locate the following parts:

- Collection Drum Cover (Parts List #7A) (Fig. 26)
- Hardware (pre-installed on Separator Funnel)
- 13mm Wrench (Included)

1. Install one M8 Hex Nut (#19A) and one M8 Washer (#22A) on the threaded shaft end (#24A) of each Locking Handle (#31A). Fig. 27.

2. Slide each threaded shaft through the two holes in the Collection Drum Cover. Using another M8 Nut and M8 Washer secure the Collection Drum Cover from the underside to the two locking handle threaded shafts. Fig. 27.

**NOTE:** Do not tighten nuts fully until the Collection Drum is assembled in the next steps. Leave loose for future adjustment to ensure a good dust seal.

## ASSEMBLING THE COLLECTION DRUM

Locate the following parts:

- Collection Drum (B - Page 8, Parts List #12A)
- Casters (x4) (E - Page 9, Parts List #18A)
- Hardware (pre-installed on casters)
- 13mm Wrench (Included)

1. Install one M8 Hex Nut (#19A) to the threaded shaft of a caster. Repeat for other casters. Fig. 28.
2. Thread the caster into the bottom of the Collection Drum. Repeat for other casters. Fig. 28.

CONTINUED ON PAGE 17

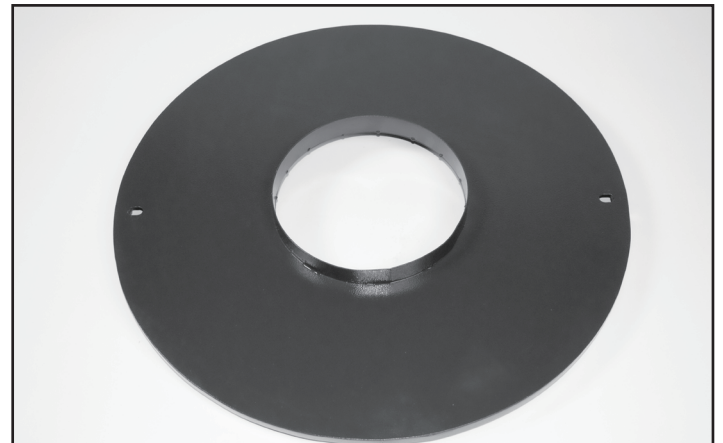

FIG. 26

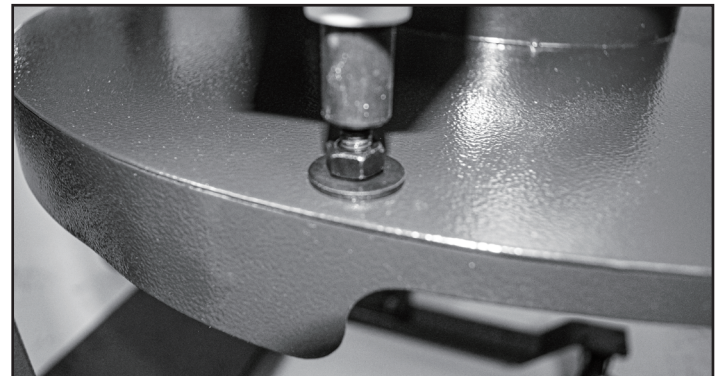

FIG. 27



FIG. 28

# ASSEMBLY

CONTINUED FROM PAGE 16

3. From inside the Collection Drum, install the Cap Nut (#13A) (x4) to each protruding threaded shaft. This will protect the plastic collection bag from damage. Figure 29.

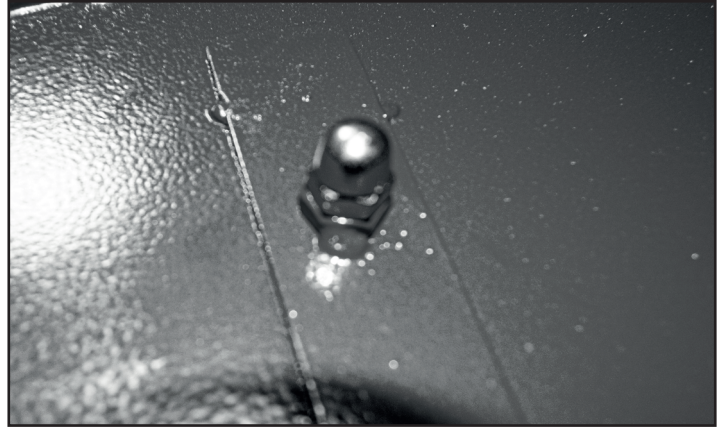

FIG. 29

## INSTALLING THE COLLECTION DRUM PLASTIC DUST BAG

1. Install the (larger) clear plastic collection bag (H - Page 8) in the Collection Drum.

2. Slide the Steel Ring (#8A) inside the clear plastic collection bag, making sure not to cut or damage the bag. The Steel Ring acts as a weight to prevent the bag from being pulled into the Impeller by suction. Figure 30.



FIG. 30

## COLLECTION DRUM FINAL ASSEMBLY

1. Roll the Collection Drum into position under the Collection Drum Cover. Secure the Collection Drum Cover to the Collection Drum with the two locking handles. Fig. 31.

2. Adjust the tension of the Collection Drum Cover to the Collection Drum with the hardware shown on page 16, Figure 27. This step will ensure a good dust seal.

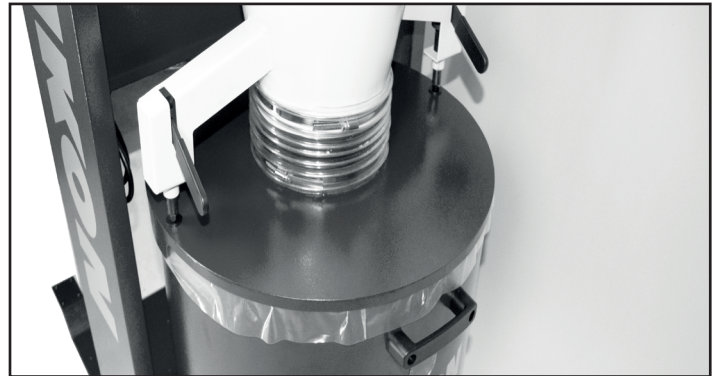

FIG. 31

3. Install the hose connecting the Collection Drum Assembly to the Separator Funnel. Fig. 32.

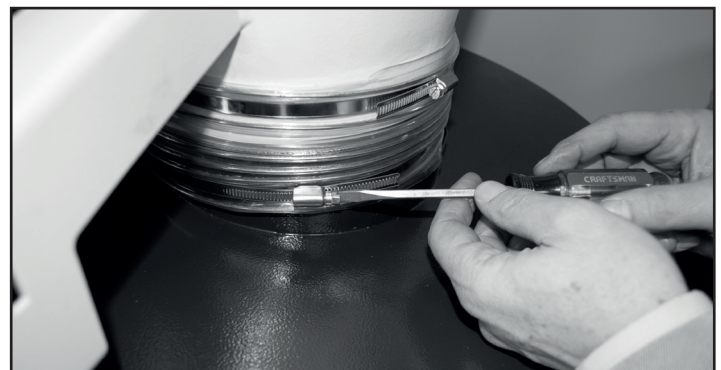

FIG. 32

## ASSEMBLY

### INSTALLING THE INLET

60-1750: 2 @ 4"

60-2500: 3 @ 4"

Install the Inlet to the Cyclonic Separator with three M6X16 Hex Socket Flat Round Head Screws (#4A) and three M6 Hex Lock Nuts (#3A). Fig. 33.



FIG. 33

## OPERATION

### ON/OFF SWITCH

**CAUTION:** Make sure that the On/Off switch is in the "Off" position before plugging the dust collector into a power source.

To operate the dust collector, press the top, round 'ON' button in to its full depth to turn the unit on.

Once work is finished, hit the bottom red safety paddle switch to turn the dust collector 'OFF'. Fig. 34.

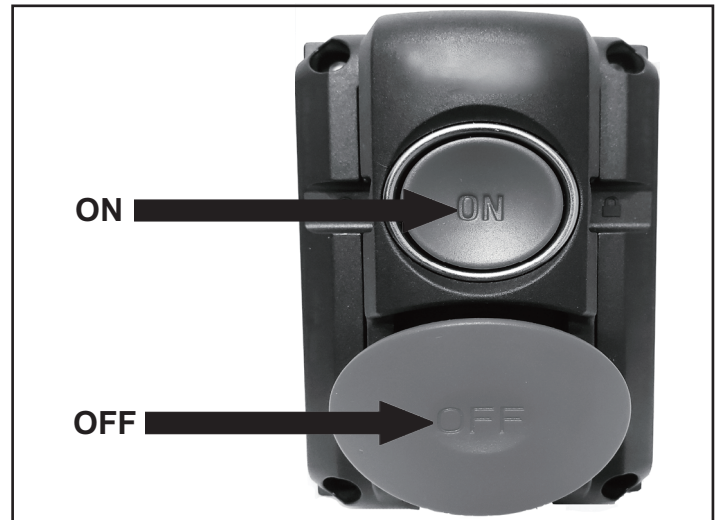

FIG. 34

RIKON® Cyclone Dust Collectors are equipped with remote control start/stop functions that operate on Bluetooth® RF band technology which increases range and ability to operate the unit from a different room. Range and operability depend on building type and density. Fig. 35.

The remote operates the dust collector the same as the main On/Off switch shown above in Figure 34.



FIG. 35

# DUST HAZARDS AND SAFETY

## EMPTYING & CLEANING THE DUST COLLECTOR

**CAUTION:** Make sure the dust collector is unplugged before cleaning or servicing. Always wear a dust mask or respirator while emptying the collector bags or cleaning the dust collector. Please refer to the California Proposition 65 warning on page 7 of this manual regarding hazards from exposure to wood dust. For more detailed information visit [www.P65Warnings.ca.gov/wood](http://www.P65Warnings.ca.gov/wood).

## GROUNDING THE DUCT WORK

**NOTE:** For permanent dust collector set-ups, the following instructions are recommended. For the occasional use of any dust collector, care must none-the-less be taken to keep the hose and bag clean.

Dust particles moving through flexible or rigid plastic duct work can cause static electricity build-up. The duct work must be properly grounded to ensure that static discharge does not ignite fine dust particles causing an explosion or fire.

To properly ground *plastic* duct work, simply run a small gauge bare copper wire through the ducting and have it emerge from the hose at the dust collector and at each dust producing machine. The bare copper wire should be bonded to the metal shell of each machine by means of a metal screw. The screw must be threaded into the metal shell to ensure a good connection.

The grounding of *metal* duct work is similar, the only difference is that there is no need to run the bare copper wire inside the ducting. It can be wrapped along the outside of the ducting and should be bonded to each machine as described above.

## WIRING DIAGRAM

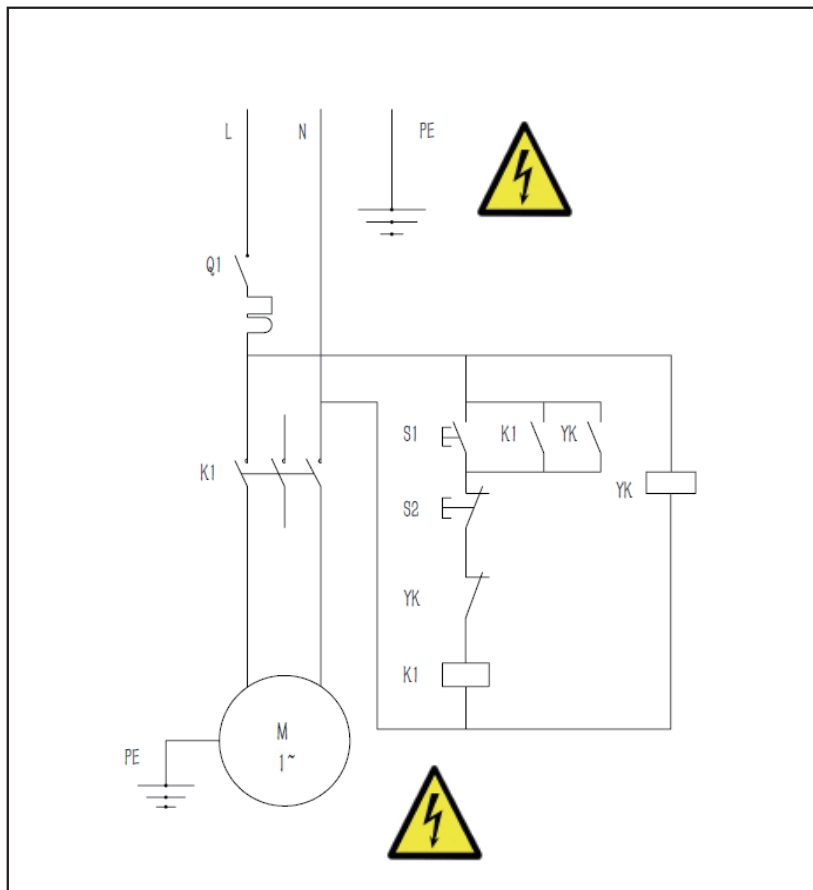

## TROUBLESHOOTING

PROBLEM	POSSIBLE CAUSE	SOLUTION
Motor does not start	<ol style="list-style-type: none"> <li>1. Machine not plugged in.</li> <li>2. Power switch in 'OFF' position.</li> <li>3. Power switch or cord is faulty.</li> <li>4. Fuse or circuit breaker are open.</li> <li>5. Low line voltage.</li> <li>6. Defective motor capacitor.</li> <li>7. Motor does not work.</li> </ol>	<ol style="list-style-type: none"> <li>1. Plug cord into electrical outlet.</li> <li>2. Lift switch to 'ON' position. The safety key must be in place. See page 11.</li> <li>3. Replace switch or cord.</li> <li>4. Correct overloaded electrical circuit.</li> <li>5. Correct low line voltage condition.</li> <li>6. Replace motor capacitor.</li> <li>7. Repair or replace the motor.</li> </ol>
Motor runs hot	<ol style="list-style-type: none"> <li>1. Restricted air flow due to dirty filter or blockage in the hoses.</li> <li>2. Motor overloaded.</li> <li>3. Extension cord is used.</li> <li>4. Machine used for extended time.</li> <li>5. Poor air flow in work area.</li> </ol>	<ol style="list-style-type: none"> <li>1. Clean filter and hoses for maximum air flow through the system.</li> <li>2. Reduce load on the motor.</li> <li>3. Do not use an extension cord. Plug the collector directly into an outlet.</li> <li>4. Reduce run time of machine.</li> <li>5. Reposition machine for better air flow.</li> </ol>
Motor stalls or does not have full power	<ol style="list-style-type: none"> <li>1. Incorrect line voltage.</li> <li>2. Motor capacitor has failed.</li> <li>3. Extension cord is being used.</li> <li>4. Impeller is clogged with debris.</li> </ol>	<ol style="list-style-type: none"> <li>1. Have qualified electrician check circuit for proper line voltage.</li> <li>2. Replace motor capacitor.</li> <li>3. Do not use an extension cord. Plug the collector directly into an outlet.</li> <li>4. Clean debris from blocked impeller.</li> </ol>
Reduction of dust collection suction power	<ol style="list-style-type: none"> <li>1. Malfunction of the filter cleaning system.</li> <li>2. Plugged hose lines.</li> <li>3. Retaining of dust in the collector due to low density.</li> <li>4. Wetting of filter.</li> <li>5. Filter is dirty or permeability of the cloth has increased.</li> </ol>	<ol style="list-style-type: none"> <li>1. Check all system components.</li> <li>2. Check and clean inlets and hoses for obstructions.</li> <li>3. Clean or replace filter and check all connections for leakage.</li> <li>4. Control intake of moisture. Dry wet filter.</li> <li>5. Clean or replace filter.</li> </ol>
Loud or unusual noises from motor or fan	<ol style="list-style-type: none"> <li>1. Motor, fan housing, base or parts of the frame are loose.</li> <li>2. Impeller fan is rubbing the housing.</li> <li>3. Motor bearings are loud.</li> <li>4. Impeller fan is loose, unbalanced, or damaged.</li> </ol>	<ol style="list-style-type: none"> <li>1. Inspect and tighten all parts or replace as needed.</li> <li>2. Check position of the fan and adjust or replace any loose/damaged parts.</li> <li>3. Replace worn bearings.</li> <li>4. Secure fan on motor shaft, and replace if any damage is found.</li> </ol>

## ACCESSORIES



### **CLEAR PLASTIC BAGS - PACK OF 5 EACH**

- 60-910 Dust Bucket Bag for RIKON 60-1750
- 60-911 Filter Element Plastic Bag for 60-1750
- 60-913 Dust Bucket Bag for RIKON 60-2500
- 60-912 Filter Element Plastic Bag for 60-2500

To order replacement parts or accessories for the Cyclone Dust Collectors or other RIKON machines, contact your local RIKON Distributor, or visit the RIKON website at [www.rikontools.com](http://www.rikontools.com).



# CD200A PARTS DIAGRAM A

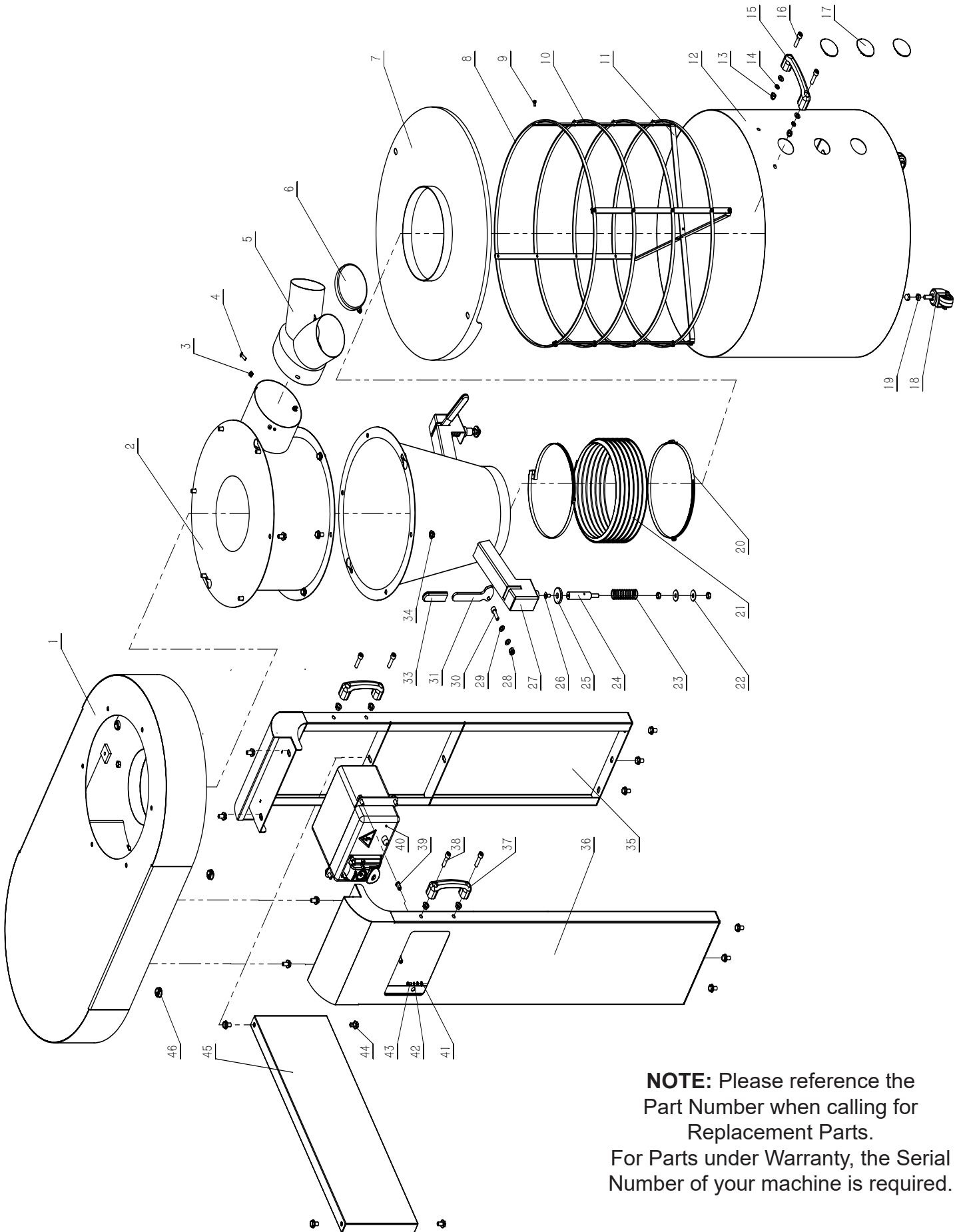

**NOTE:** Please reference the Part Number when calling for Replacement Parts.  
For Parts under Warranty, the Serial Number of your machine is required.

## CD200A PARTS LIST A

KEY NO.	DESCRIPTION	QTY.	PART NO.
1	Dust Plenum	1	P60-1750-1A
2	Cyclonic Separator	1	P60-1750-2A
3	Hex lock nut M6	3	P60-1750-3A
4	Hex socket flat round hd screw M6X16	3	P60-1750-4A
5	Inlet	1	P60-1750-5A
6	Muti-Way Connector cover	1	P60-1750-6A
7	Collection Drum Cover	1	P60-1750-7A
8	Steel ring	4	P60-1750-8A
9	Cross recessed pan head screw M5X8	20	P60-1750-9A
10	Vertical column	4	P60-1750-10A
11	Base plate brace	2	P60-1750-11A
12	Collection Drum	1	P60-1750-12A
13	Cap nut M8	6	P60-1750-13A
14	Spring washer 8	2	P60-1750-14A
15	Handle	1	P60-1750-15A
16	Hex socket head cap screw M8X30	2	P60-1750-16A
17	Clear window	3	P60-1750-17A
18	Caster wheel	4	P60-1750-18A
19	Hex nut M8	8	P60-1750-19A
20	Hose clamps	2	P60-1750-20A
21	Pipe	1	P60-1750-21A
22	Big washer 8	4	P60-1750-22A
23	Compression spring	2	P60-1750-23A
24	Threaded rod	2	P60-1750-24A
25	Plate	2	P60-1750-25A
26	Hex socket countersunk hd scr M6X16	2	P60-1750-26A
27	Separator Funnel	1	P60-1750-27A
28	Hex lock nut M8	2	P60-1750-28A
29	Flat washer 8	6	P60-1750-29A
30	Hex socket head cap screw M8X25	2	P60-1750-30A
31	Handle	2	P60-1750-31A
32	Flat washer 4	1	P60-1750-32A
33	Handle sleeve	2	P60-1750-33A
34	Hex flange nut M8	10	P60-1750-34A
35	Right Support Panel	1	P60-1750-35A
36	Left Support Panel	1	P60-1750-36A
37	Handle	2	P60-1750-37A
38	Hex socket head cap screw M8X30	4	P60-1750-38A
39	Flat head hex rivet nut M6X15	4	P60-1750-39A
40	Switch box assembly	1	P60-1750-40A
41	Washer 5	1	P60-1750-41A
42	Spring washer 4	1	P60-1750-42A
43	Cross recessed pan hd screw M4X12	1	P60-1750-43A
44	Hex head flange bolt M8X16	26	P60-1750-44A
45	Panel Cross Brace	1	P60-1750-45A
46	End cap	4	P60-1750-46A

# CD200A PARTS DIAGRAM B

**NOTE:** Please reference the Part Number when calling for Replacement Parts.  
For Parts under Warranty, the Serial Number of your machine is required.

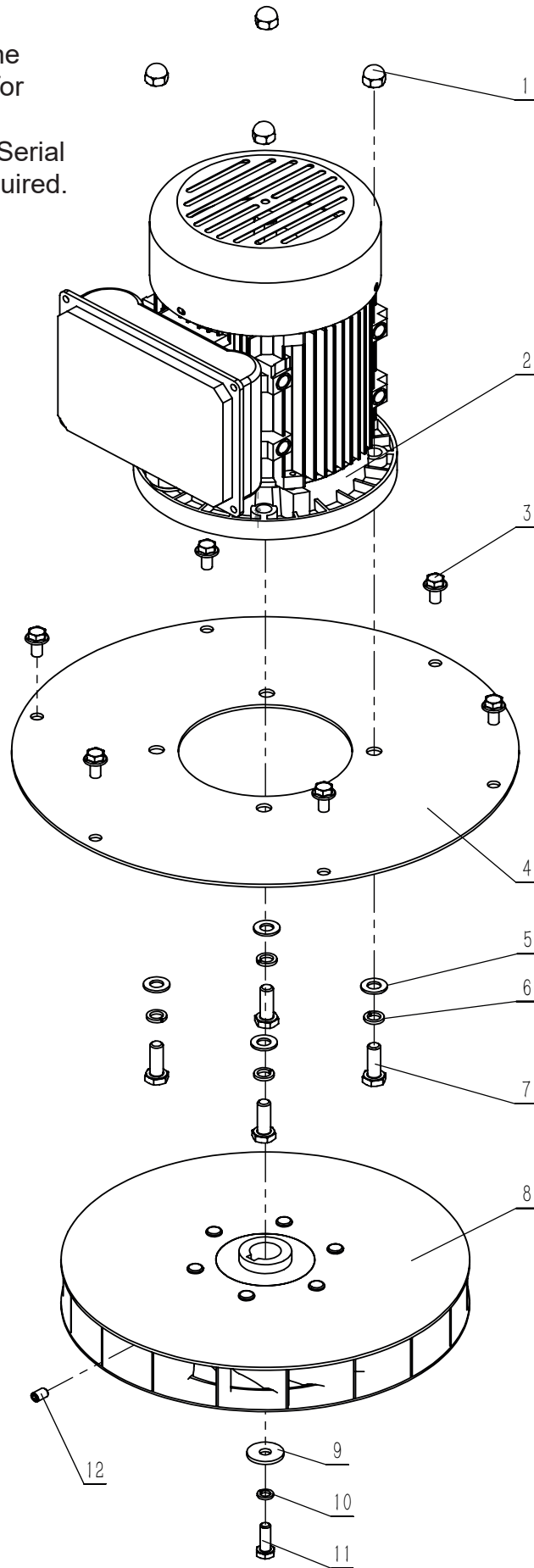

## CD200A PARTS LIST B

KEY NO.	DESCRIPTION	QTY.	PART NO.
1	Cap nut M10	4	P60-1750-1B
2	Motor	1	P60-1750-2B
3	Hex head flange bolt M8X16	6	P60-1750-3B
4	Motor mounting plate	1	P60-1750-4B
5	Flat washer 10	4	P60-1750-5B
6	Spring washer 10	4	P60-1750-6B
7	Hex headed bolt M10X30	4	P60-1750-7B
8	Impeller	1	P60-1750-8B
9	Big washer 8	1	P60-1750-9B
10	Spring washer 8	1	P60-1750-10B
11	Hex headed bolt M8X25	1	P60-1750-11B
12	Hex socket flat end set screw M8X12	1	P60-1750-12B

**NOTE:** Please reference the Part Number when calling for Replacement Parts.  
For Parts under Warranty, the Serial Number of your machine is required.

# CD200A PARTS DIAGRAM C

**NOTE:** Please reference the Part Number when calling for Replacement Parts.  
For Parts under Warranty, the Serial Number of your machine is required.

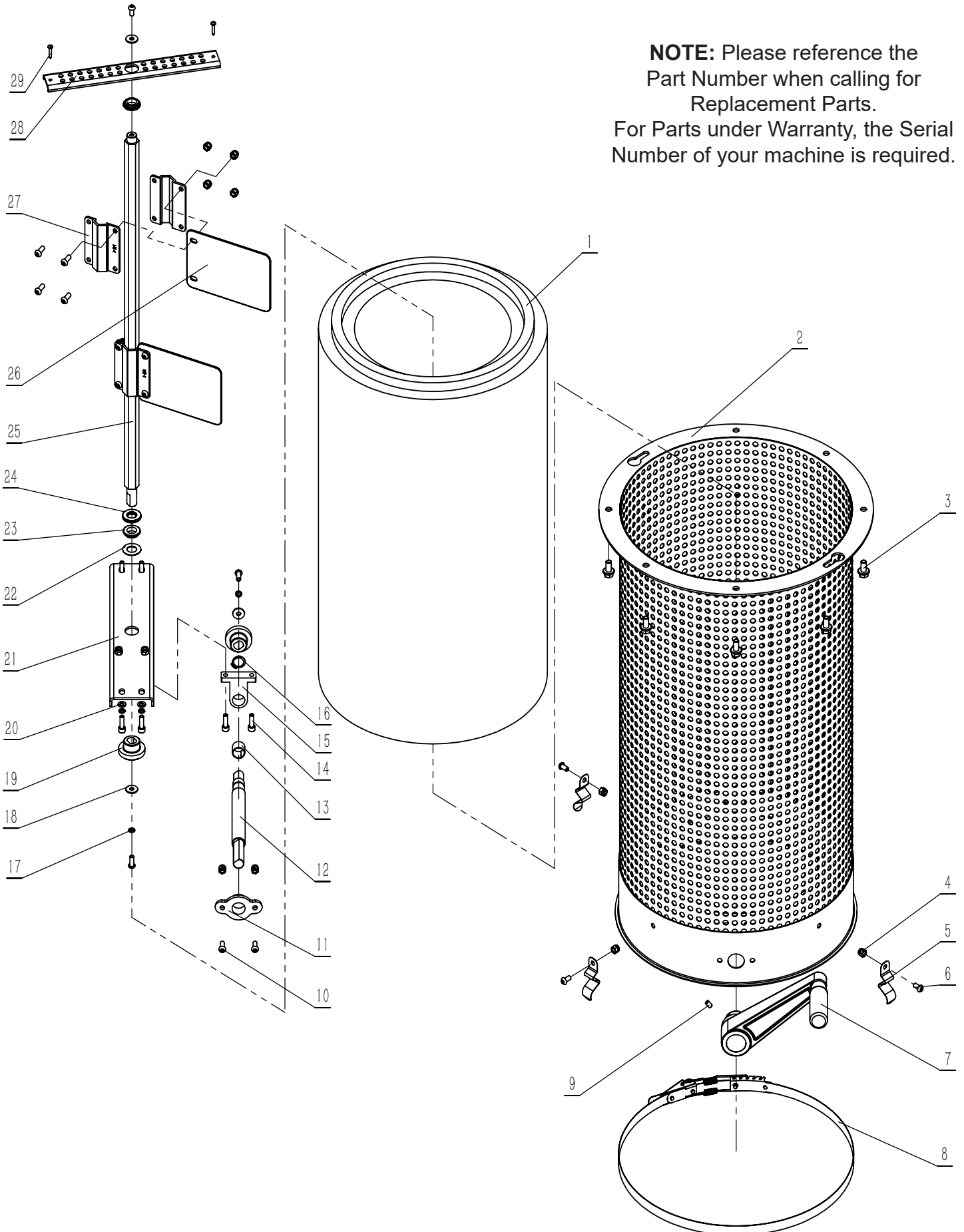

## CD200A PARTS LIST C

KEY NO.	DESCRIPTION	QTY.	PART NO.
1	Filter cartridge	1	P60-1750-1C
2	Filter cartridge shield	1	P60-1750-2C
3	Hex head flange bolt M8X16	8	P60-1750-3C
4	Hex lock nut M6	15	P60-1750-4C
5	Spring clip	3	P60-1750-5C
6	Hex socket flat round hd screw M6X12	4	P60-1750-6C
7	Handle	1	P60-1750-7C
8	Clamping assembly	1	P60-1750-8C
9	Hex socket flat end set screw M6X10	1	P60-1750-9C
10	Hex socket flat round hd screw M6X16	12	P60-1750-10C
11	Positioning sleeve	1	P60-1750-11C
12	Rotation shaft	1	P60-1750-12C
13	Shaft sleeve	1	P60-1750-13C
14	Hex socket head cap screw M6X20	6	P60-1750-14C
15	Guide sleeve	1	P60-1750-15C
16	Circlip	1	P60-1750-16C
17	Spring washer 6	6	P60-1750-17C
18	Big washer 6	3	P60-1750-18C
19	Gear	2	P60-1750-19C
20	Flat washer 6	4	P60-1750-20C
21	Lower support plate	1	P60-1750-21C
22	Washer	1	P60-1750-22C
23	Sleeve gasket	2	P60-1750-23C
24	Bearing	1	P60-1750-24C
25	Dust remove shaft	1	P60-1750-25C
26	Dust remove plate	2	P60-1750-26C
27	Dust remove bracket	4	P60-1750-27C
28	Upper fixing plate	1	P60-1750-28C
29	Cross recessed pan head tapping screw	2	P60-1750-29C

**NOTE:** Please reference the  
Part Number when calling for  
Replacement Parts.  
For Parts under Warranty, the Serial  
Number of your machine is required.

## CD200A PARTS DIAGRAM D

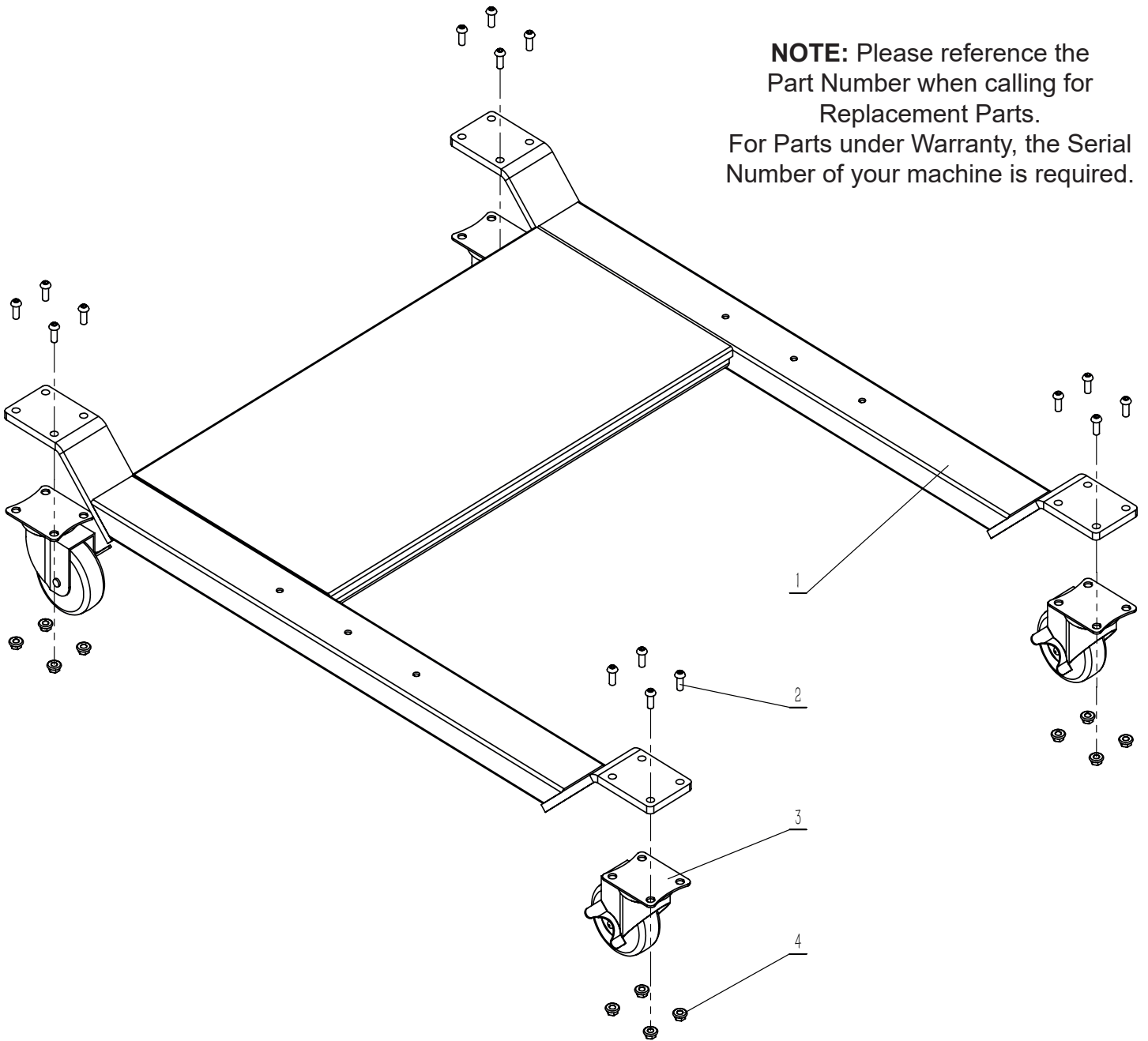

**NOTE:** Please reference the Part Number when calling for Replacement Parts.  
For Parts under Warranty, the Serial Number of your machine is required.

## CD200A PARTS LIST D

KEY NO.	DESCRIPTION	QTY.	PART NO.
1	Base bracket	1	P60-1750-1D
2	Hex socket flat round hd screw M6X16	16	P60-1750-2D
3	Caster wheel	4	P60-1750-3D
4	Hex flange nut M6	16	P60-1750-4D



# CD300A PARTS DIAGRAM A

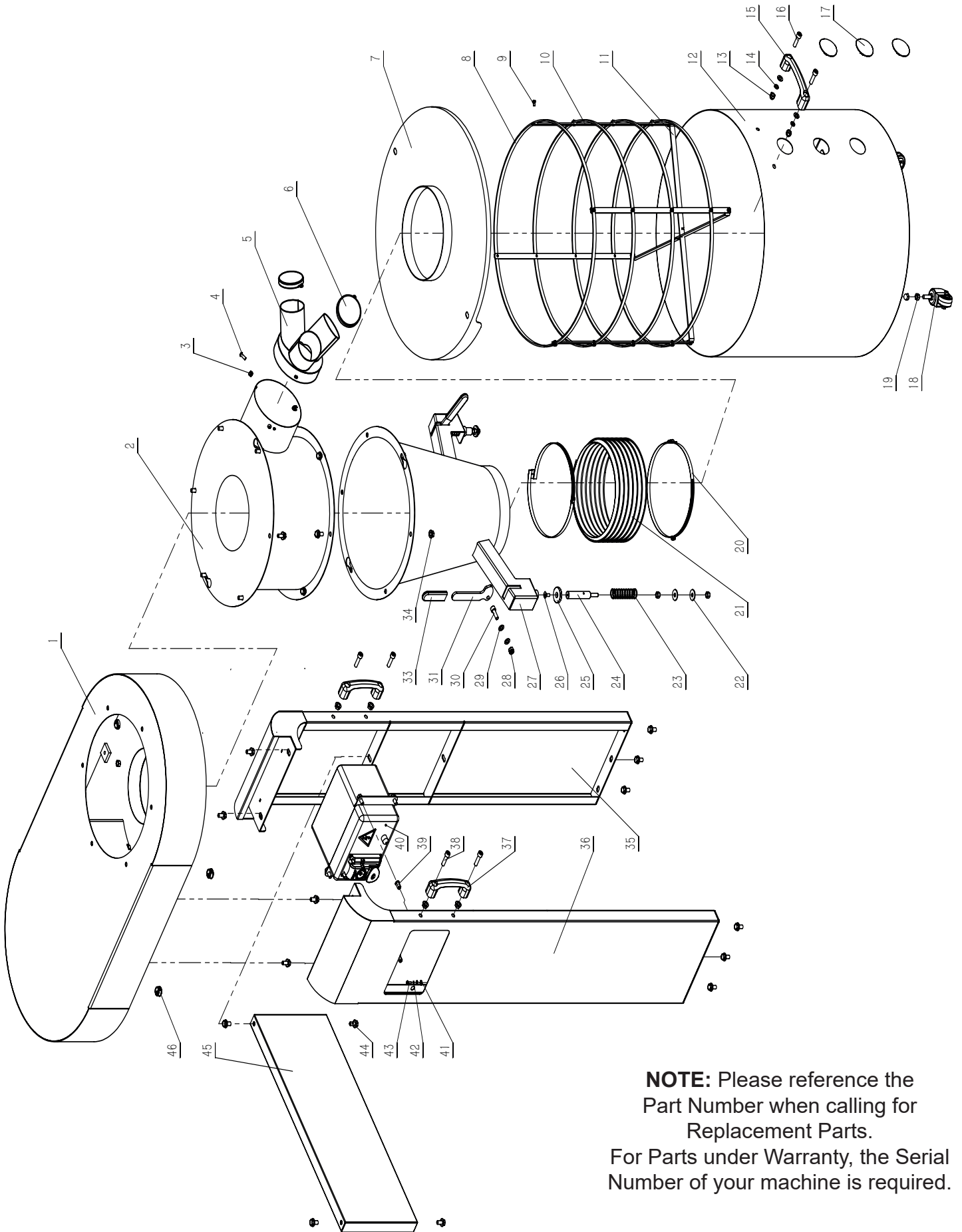

**NOTE:** Please reference the Part Number when calling for Replacement Parts. For Parts under Warranty, the Serial Number of your machine is required.

## CD300A PARTS LIST A

KEY NO.	DESCRIPTION	QTY.	PART NO.
1	Dust Plenum	1	P60-2500-1A
2	Cyclonic Separator	1	P60-2500-2A
3	Hex lock nut M6	3	P60-2500-3A
4	Hex socket flat round hd screw M6X16	3	P60-2500-4A
5	Inlet	1	P60-2500-5A
6	Muti-Way Connector cover	1	P60-2500-6A
7	Collection Drum Cover	1	P60-2500-7A
8	Steel ring	4	P60-2500-8A
9	Cross recessed pan head screw M5X8	20	P60-2500-9A
10	Vertical column	4	P60-2500-10A
11	Base plate brace	2	P60-2500-11A
12	Collection Drum	1	P60-2500-12A
13	Cap nut M8	6	P60-2500-13A
14	Spring washer 8	2	P60-2500-14A
15	Handle	1	P60-2500-15A
16	Hex socket head cap screw M8X30	2	P60-2500-16A
17	Clear window	3	P60-2500-17A
18	Caster wheel	4	P60-2500-18A
19	Hex nut M8	8	P60-2500-19A
20	Hose clamps	2	P60-2500-20A
21	Pipe	1	P60-2500-21A
22	Big washer 8	4	P60-2500-22A
23	Compression spring	2	P60-2500-23A
24	Threaded rod	2	P60-2500-24A
25	Plate	2	P60-2500-25A
26	Hex socket countersunk hd scr M6X16	2	P60-2500-26A
27	Separator Funnel	1	P60-2500-27A
28	Hex lock nut M8	2	P60-2500-28A
29	Flat washer 8	6	P60-2500-29A
30	Hex socket head cap screw M8X25	2	P60-2500-30A
31	Handle	2	P60-2500-31A
32	Flat washer 4	1	P60-2500-32A
33	Handle sleeve	2	P60-2500-33A
34	Hex flange nut M8	10	P60-2500-34A
35	Right Support Panel	1	P60-2500-35A
36	Left Support Panel	1	P60-2500-36A
37	Handle	2	P60-2500-37A
38	Hex socket head cap screw M8X30	4	P60-2500-38A
39	Flat head hex rivet nut M6X15	4	P60-2500-39A
40	Switch box assembly	1	P60-2500-40A
41	Washer 5	1	P60-2500-41A
42	Spring washer 4	1	P60-2500-42A
43	Cross recessed pan hd screw M4X12	1	P60-2500-43A
44	Hex head flange bolt M8X16	26	P60-2500-44A
45	Panel Cross Brace	1	P60-2500-45A
46	End cap	4	P60-2500-46A

# CD300A PARTS DIAGRAM B

**NOTE:** Please reference the Part Number when calling for Replacement Parts.  
For Parts under Warranty, the Serial Number of your machine is required.

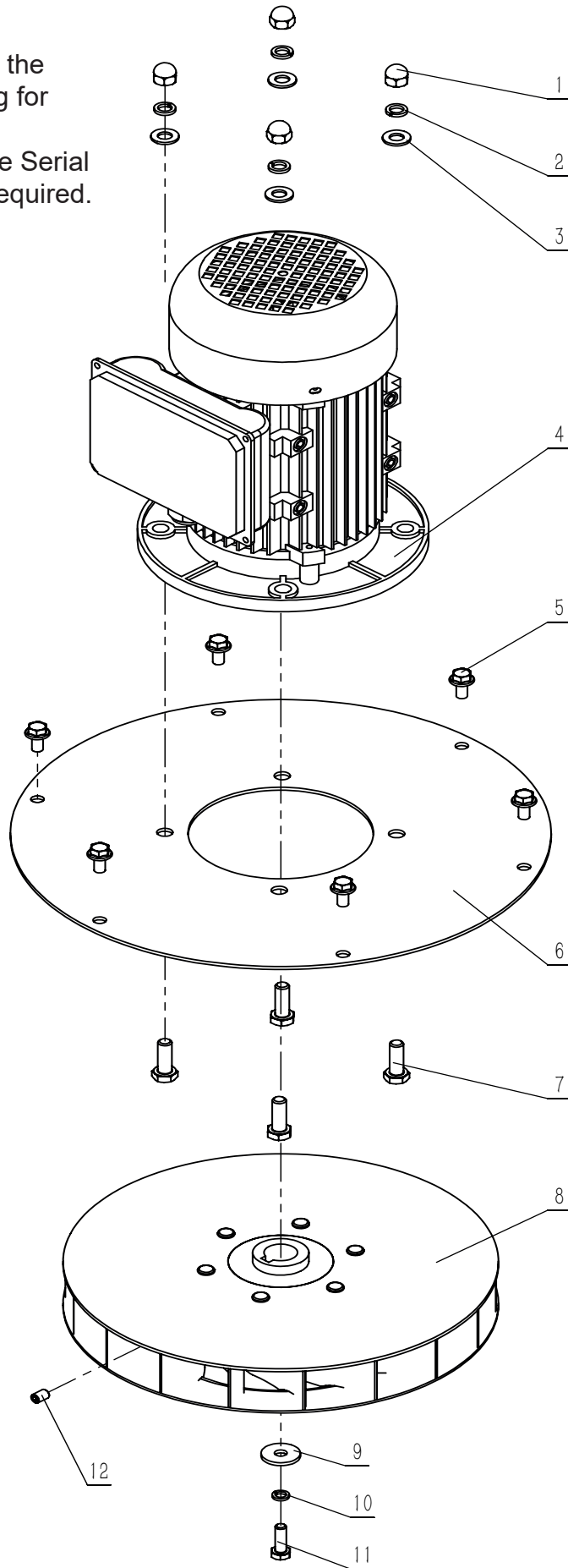

## CD300A PARTS LIST B

KEY NO.	DESCRIPTION	QTY.	PART NO.
1	Cap nut M10	4	P60-2500-1B
2	Spring washer 10	1	P60-2500-2B
3	Flat washer 10	6	P60-2500-3B
4	Motor	1	P60-2500-4B
5	Hex head flange bolt M8X16	4	P60-2500-5B
6	Motor mounting plate	4	P60-2500-6B
7	Hex headed bolt M10X30	4	P60-2500-7B
8	Impeller	1	P60-2500-8B
9	Big washer 8	1	P60-2500-9B
10	Spring washer 8	1	P60-2500-10B
11	Hex headed bolt M8X25	1	P60-2500-11B
12	Hex socket flat end set screw M8X12	1	P60-2500-12B

**NOTE:** Please reference the Part Number when calling for Replacement Parts.  
For Parts under Warranty, the Serial Number of your machine is required.

# CD300A PARTS DIAGRAM C

**NOTE:** Please reference the Part Number when calling for Replacement Parts.  
For Parts under Warranty, the Serial Number of your machine is required.

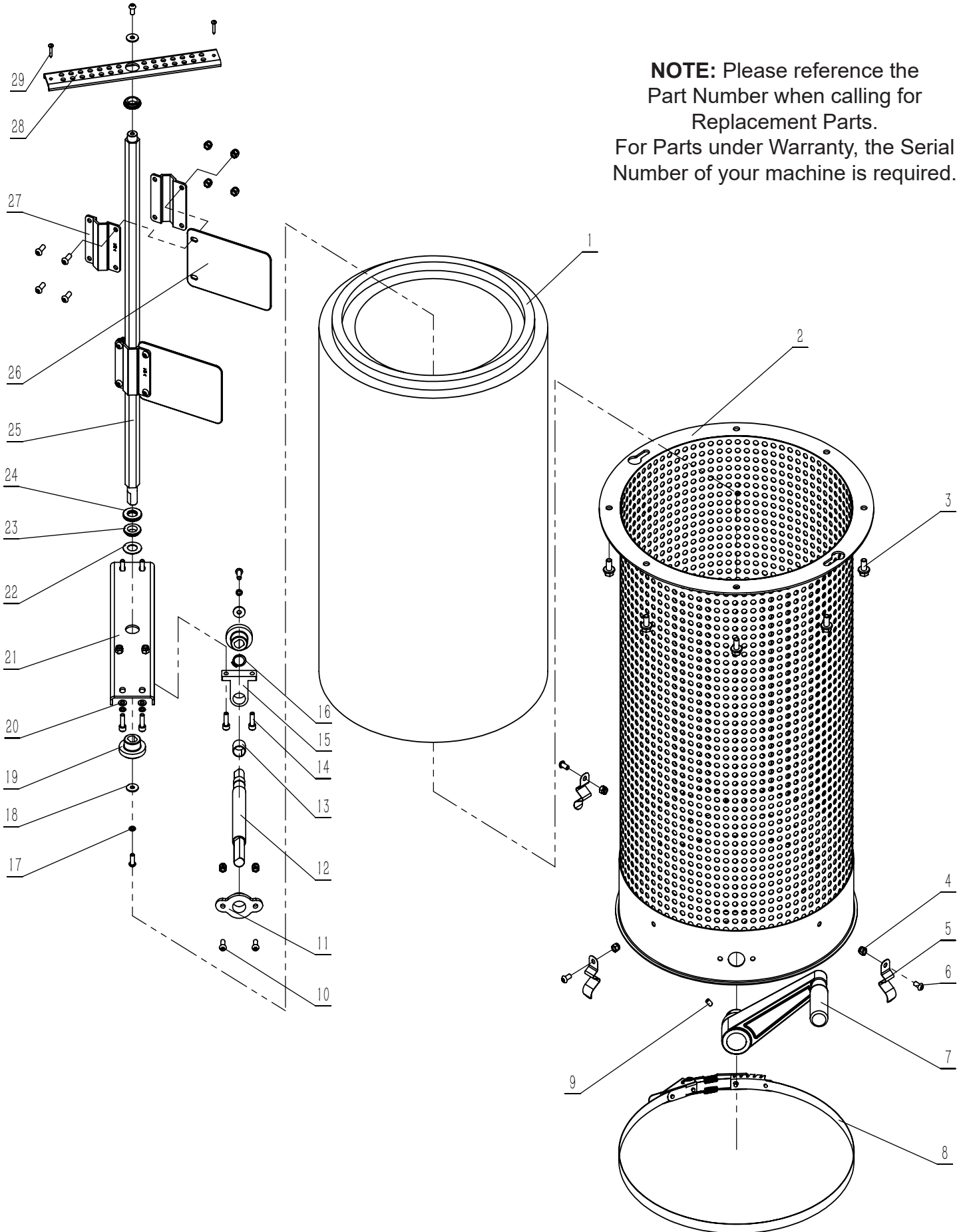

## CD300A PARTS LIST C

KEY NO.	DESCRIPTION	QTY.	PART NO.
1	Filter cartridge	1	P60-2500-1C
2	Filter cartridge shield	1	P60-2500-2C
3	Hex head flange bolt M8X16	8	P60-2500-3C
4	Hex lock nut M6	15	P60-2500-4C
5	Spring clip	3	P60-2500-5C
6	Hex socket flat round hd screw M6X12	4	P60-2500-6C
7	Handle	1	P60-2500-7C
8	Clamping assembly	1	P60-2500-8C
9	Hex socket flat end set screw M6X10	1	P60-2500-9C
10	Hex socket flat round hd screw M6X16	12	P60-2500-10C
11	Positioning sleeve	1	P60-2500-11C
12	Rotation shaft	1	P60-2500-12C
13	Shaft sleeve	1	P60-2500-13C
14	Hex socket head cap screw M6X20	6	P60-2500-14C
15	Guide sleeve	1	P60-2500-15C
16	Circlip	1	P60-2500-16C
17	Spring washer 6	6	P60-2500-17C
18	Big washer 6	3	P60-2500-18C
19	Gear	2	P60-2500-19C
20	Flat washer 6	4	P60-2500-20C
21	Lower support plate	1	P60-2500-21C
22	Washer	1	P60-2500-22C
23	Sleeve gasket	2	P60-2500-23C
24	Bearing	1	P60-2500-24C
25	Dust remove shaft	1	P60-2500-25C
26	Dust remove plate	2	P60-2500-26C
27	Dust remove bracket	4	P60-2500-27C
28	Upper fixing plate	1	P60-2500-28C
29	Cross recessed pan head tapping screw	2	P60-2500-29C

**NOTE:** Please reference the  
Part Number when calling for  
Replacement Parts.  
For Parts under Warranty, the Serial  
Number of your machine is required.

## CD300A PARTS DIAGRAM D

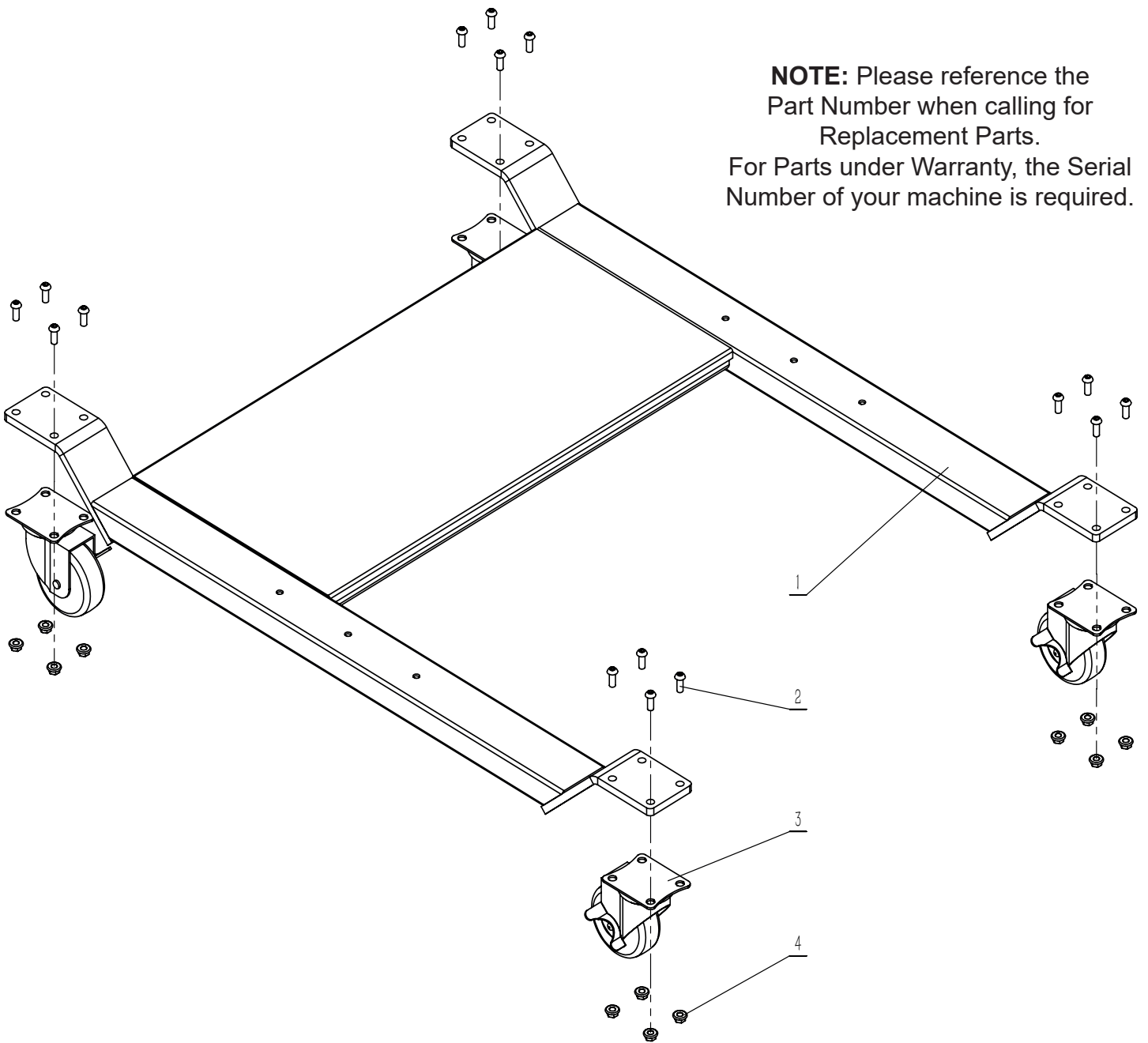

**NOTE:** Please reference the Part Number when calling for Replacement Parts.  
For Parts under Warranty, the Serial Number of your machine is required.

## CD300A PARTS LIST D

KEY NO.	DESCRIPTION	QTY.	PART NO.
1	Base bracket	1	P60-2500-1D
2	Hex socket flat round hd screw M6X16	16	P60-2500-2D
3	Caster wheel	4	P60-2500-3D
4	Hex flange nut M6	16	P60-2500-4D



# Declaration of Conformity



Nationality	
<b>GB</b>	The object of the declaration described is in conformity with the relevant GB/EU legislation.
<b>DE</b>	Der Gegenstand der beschriebenen Erklärung stimmt mit den einschlägigen GB/EU-Rechtsvorschriften überein.
<b>FR</b>	L'objet de la déclaration décrite est conforme à la législation GB/UE pertinente.
<b>IT</b>	L'oggetto della dichiarazione descritta è conforme alla legislazione GB/UE pertinente.
<b>ES</b>	El objeto de la declaración descrita está en conformidad con la legislación GB/UE pertinente.
<b>NL</b>	Het voorwerp van de beschreven verklaring is in overeenstemming met de relevante GB/EU-wetgeving.
<b>DK</b>	Genstanden for den beskrevne erklæring er i overensstemmelse med den relevante GB/EU-lovgivning.
<b>SE</b>	Föremålet för den beskrivna deklARATIONEN överensstämmer med den relevanta GB/EU-lagstiftningen.
<b>CZ</b>	Předmět popsaného prohlášení je v souladu s příslušnými právními předpisy GB/EU.
<b>PL</b>	Przedmiot opisanej deklaracji jest zgodny z odpowiednimi przepisami GB/UE.
<b>POR</b>	O objeto da declaração descrita está em conformidade com a legislação GB/UE relevante.
<b>NOR</b>	Gjenstanden for den beskrevne erklæringen er i samsvar med den relevante GB/EU-lovgivningen.
<b>FI</b>	Määritellyn ilmoituksen kohde on asiaankuuluvan Ison-Britannian/EU: n lainsäädännön mukainen.
<b>IS</b>	Hluturinn í lýsingunni er í samræmi við viðeigandi lög GB/ESB.

Object of the Declaration: Axminster Professional SD2080CE Dust Extractor		
<p><b>UK:</b> Supply of Machinery (Safety) Regulations 2008 as amended Electromagnetic Compatibility Regulations 2016 as amended</p>	<p><b>EU:</b> Machinery Directive 2006/42/EC EMC Directive 2014/35/EU</p>	<p><b>UK Address:</b> Newhow Limited. Trading as Axminster Tools Weycroft Avenue Axminster. Devon EX13 5PH</p>
<p><b>Standards used or references to the other technical specifications in relation to which conformity is declared:</b> EN 60204-1:2018, ISO 12100:2010 IEC 61000-6-4:2019 &amp; IEC 61000-6-2:2019</p>		<p><b>European Address:</b> Newhow Limited. Trading as Axminster Tools A-201. Haagsche Hof Parkstraat 83 The Hague 2514 JG Netherlands</p>
<p><b>Date:</b> 11/1/2025 <b>Place:</b> Axminster</p>	 Charlie Cross Operations Director	